



Science for Environment Policy

IN-DEPTH REPORT 16

Taking stock: progress in natural capital accounting

November 2017



Environment

Science for Environment Policy

Taking stock: progress in natural capital accounting

Contents

Introduction: How ‘capital’ counts for nature	3
Potted history of natural capital accounting	10
1. Methods for natural capital accounting	17
2. Measuring ecosystem services biophysically	19
3. Economics and NCA: valuing ecosystem assets and services in national accounts	25
4. Natural capital accounting in practice: refining and testing the protocols	30
5. Conclusion	43
References	45

This In-depth Report is written and edited by the Science Communication Unit, University of the West of England (UWE), Bristol

Email: sfep.editorial@uwe.ac.uk

To cite this publication:

Science for Environment Policy (2017) *Taking stock: progress in natural capital accounting*. In-depth Report 16 produced for the European Commission, DG Environment by the Science Communication Unit, UWE, Bristol. Available at: <http://ec.europa.eu/science-environment-policy>

Acknowledgements

We wish to thank the following for their contributions to this report: Giles Atkinson, Professor of Environmental Policy, London School of Economics. Final responsibility for the content and accuracy of the report, however, lies solely with the author.

Image on facing page: Crocus alpine snow mountains, micpicee, Pixabay, 2010. CC0.

ISBN: 978-92-79-55106-2

ISSN: 2363-2798

DOI: 10.2779/304410

The contents and views included in Science for Environment Policy are based on independent research and do not necessarily reflect the position of the European Commission.

© European Union, 2017. Reproduction is authorised and encouraged, provided the source is acknowledged using the citation above. Please send any resulting outputs to sfep.editorial@uwe.ac.uk for our records.

About Science for Environment Policy

Science for Environment Policy is a free news and information service published by the European Commission's Directorate-General Environment, which provides the latest environmental policy-relevant research findings.

In-depth Reports are a feature of the service, introduced in 2012, which take a comprehensive look at the latest science for key policy topics. In addition to In-depth Reports, Science for Environment Policy also publishes a weekly **News Alert** which is delivered by email to subscribers and provides accessible summaries of key scientific studies.

<http://ec.europa.eu/science-environment-policy>

Keep up-to-date

Subscribe to Science for Environment Policy's weekly **News Alert** by emailing: sfep@uwe.ac.uk

Or sign up online at:

<http://ec.europa.eu/science-environment-policy>

Introduction

How ‘capital’ counts for nature

The growing human population and a shift to more resource-intensive habits and behaviours are increasing the demands on global ecosystems. Natural capital is a way to describe Earth’s natural assets, including soil, air, water, and living things, existing as complex ecosystems, which provide a range of services to humans. Depleting and degrading these reserves may irreversibly reduce the availability of benefits to future generations. This In-Depth Report presents an overview of ideas, debates and progress so far in natural capital accounting, in particular in accounting for ecosystems and their services.

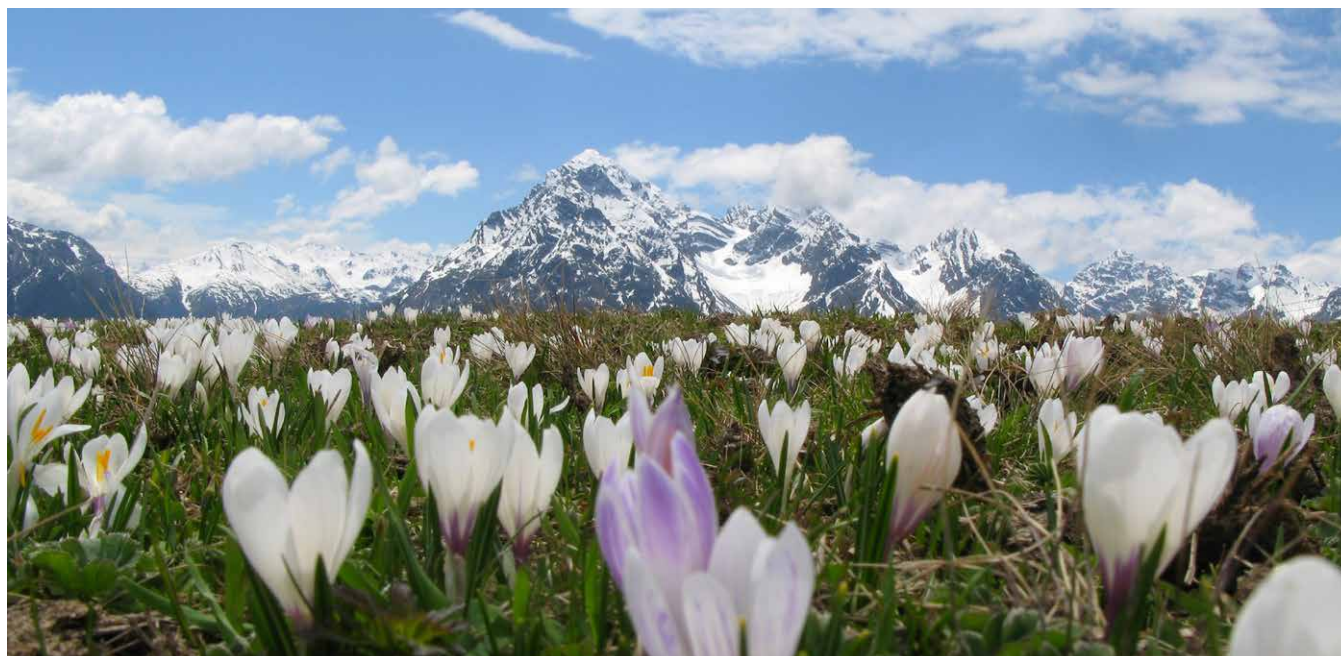

We are at a critical moment to find ways to account for natural resources and their benefits in a systematic fashion. Many ecosystems may be so far degraded that future generations may not be able to benefit from the services they provide. Many of us living in highly urbanised societies are not being made aware of nature’s full ‘worth’ or ‘value’ — its ‘capital’ — which can be seen in the great number of services nature provides. There is a risk we may not appreciate these services until nature’s capacity to provide them runs out. The most evident services are food, drinking water and plant materials used for building, cloth, medicine and fuel, but there are also myriad, less evident services, such as the organisms that help clean pollutants from air, the insects that provide natural pest control and pollination (on which approximately 84% of all European crops depend), the defences from flood,

noise and wind provided by trees, the tonnes of carbon captured and stored by soil and vegetation, the mental and physical health benefits that come from our experience of wildlife and the natural environment, and many more. Broadly speaking, ‘Natural capital’ describes all the natural assets and the related services that human societies need in order to survive and thrive.

The Millennium Ecosystem Assessment (MA), a global assessment of the consequences of ecosystem change published in 2005, found that 60% of a group of 24 ecosystem services are being degraded. One analysis of a broad set of indicators of Aichi Biodiversity Target 14 (ecosystem services restored and safeguarded; **Box 1**) supports the conclusion that there is no overall progress towards this target, and the overall ‘state’ of natural capital is in decline (Shepherd *et al.* 2016).

Box 1: Aichi Biodiversity Target 14

By 2020, ecosystems that provide essential services, including services related to water, and contribute to health, livelihoods and well-being, are restored and safeguarded, taking into account the needs of women, indigenous and local communities and the poor and vulnerable.

Societies are now depleting and degrading natural capital faster than it can regenerate and returning waste to the environment faster than it can be absorbed. Depletion and degradation of this natural capital will diminish not only nature's capacity to regenerate itself but also the raw materials needed for all economic production and the flow of ecosystem services essential to human wellbeing. Depleting an entire forest not only means the loss of that asset but also the loss of future services that it could provide. Future generations are being left dependent on dwindling resources (Farley,

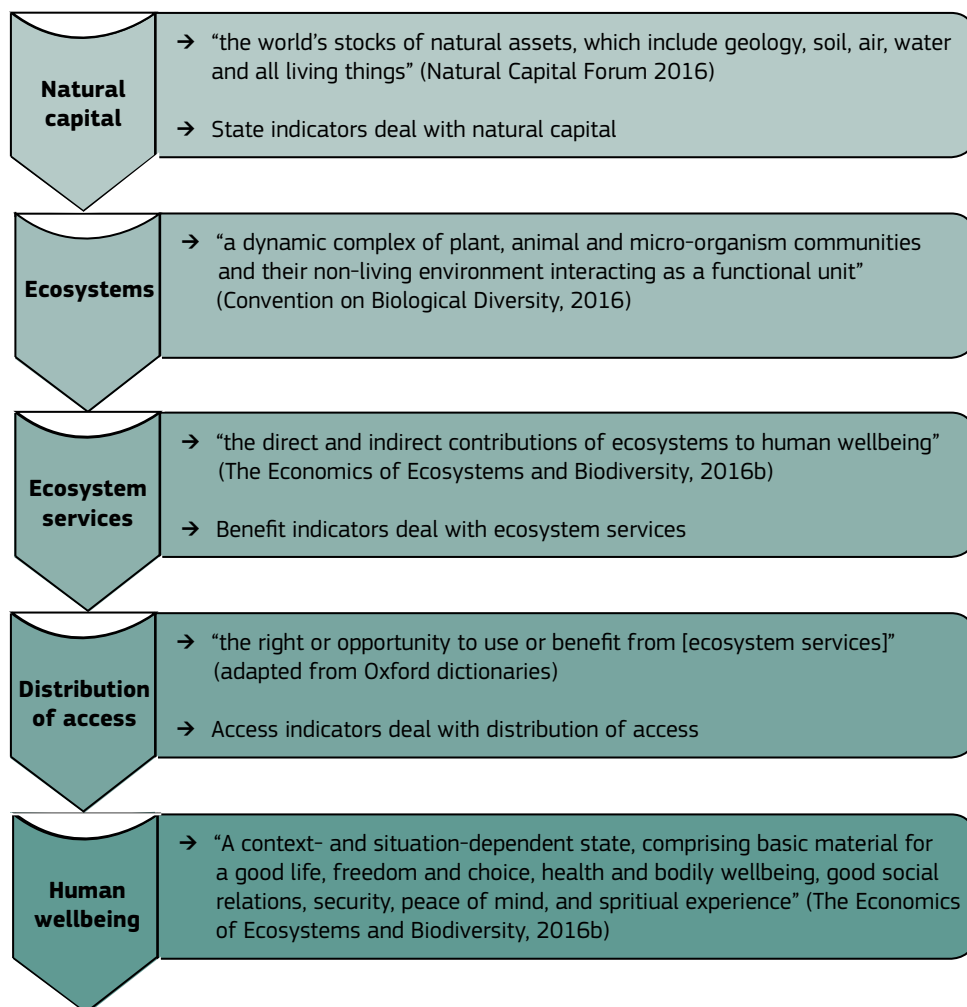

Figure 1: Basic flows from natural capital to human well-being. Source: Redrawn from Shepherd *et al.* 2016.

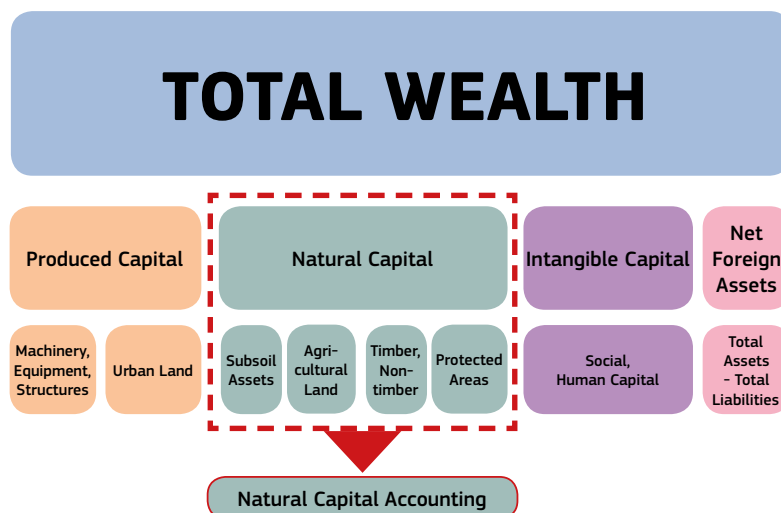

Figure 2: Comprehensive wealth composition. Source: World Bank. ‘Wealth Accounting and WAVES’, Wealth Accounting and the valuation of ecosystem services website. Available at: <http://www.wavespartnership.org>

2012). Indeed, natural systems underpin basic material conditions for life, wellbeing and all economic activity.

‘Natural capital accounting’ offers a way to create a register of the natural ‘assets’ — geology, soil, water, air and all living things — along with the range of services provided. Its purpose is to enable governments, businesses and individuals to value them sufficiently to take responsibility for maintaining and monitoring their health. Also, by including an analysis of the health of the ‘assets’ and their ability to function, it is hoped that better decisions can be made to improve them, to protect them, or simply to use them more wisely so they can continue to support future generations.

This In-Depth Report aims to:

- summarise current knowledge on natural capital accounting.
- outline the key methods under development in natural capital accounting.

i.i Why accounting?

In the broad sense of the word, accounting is essentially the systematic and comprehensive recording of items and financial transactions pertaining to a business, administration or nation. Generally, accounting involves creating a list of assets, liabilities, expenses and income; one can, in a similar way, account for nature and its services.

National accounts are a system of accounts and balance sheets that record systematic and detailed economic data that are useful to describe economies in consistent, reliable and comparable ways. For various ‘institutional sectors’ (e.g. households, corporations, NGOs, government), the system can record transactions or changes in assets during a period of time as well as the level of stocks held (at the end of a time period).

There are worldwide guidelines on national accounts, known as the system of national accounts or SNA, which are published jointly by the [United Nations](#), the [Commission of the European Communities](#), the [International Monetary Fund \(IMF\)](#), the [Organisation for Economic Co-operation and Development \(OECD\)](#) and the [World Bank](#). The SNA is an

internationally agreed set of recommendations, based on established economic conventions, comprising concepts, definitions, classifications and accounting rules that serve as the basis for a broader system of economic and social statistics. The European system of national accounts, known as ESA, is fully consistent with the SNA.

National accounts were designed expressly to provide economic data for analysis, decision- and policymaking and also provide a standard way to formulate such indicators as GDP per capita, which is the most frequently quoted measure of economic growth performance. GDP and net national product (NNP: GDP minus depreciation) are often considered to be indicators of living standards, despite the fact that the indicators were not designed to serve this purpose.

For the past 15 years, its Environment and Natural Resources Global Practice, The World Bank has attempted to measure comprehensive wealth systematically to include different kinds of capital, including natural capital. Some measures showing the sustainability of growth are published annually, such as adjusted net saving (ANS), which is used to measure the change in a country's national wealth, and adjusted net national income (aNNI), which is gross national capital, minus fixed capital and natural resources depletion. These measures try to show how much wealth the country is 'saving' for future generations and are meant to complement GDP to show a fuller picture.

In 2011, the World Bank presented a dataset of 'comprehensive wealth accounts' for over 150 countries. The World Bank concluded that the 'shadow value'¹ of natural capital made up over 20% of comprehensive wealth in 'developing' countries. More recently, they have assessed this [share at 36%](#).

The WAVES Global Partnership Program (WAVES-GPP) is a World Bank-led global partnership, launched in 2010, that aims to ensure that accounting for natural resources is mainstreamed into development planning.

WAVES-GPP works with ministries of planning, development and finance across the world to develop approaches to ecosystem accounting and build capacity to help countries to adopt and implement accounts that are relevant for policy and decisionmaking (see WAVES case studies in Section 4).

i.ii Defining and using natural capital accounting

The 7th EAP defines Natural Capital as biodiversity, including ecosystems that provide essential goods and services, from fertile soil and multi-functional forests to productive land and seas, from good quality fresh water and clean air to pollination and climate regulation and protection against natural disasters ([DECISION No 1386/2013/EU](#)). The UN's SEEA central framework defines 'environmental assets' more broadly as: mineral and energy resources, land, soil resources, timber resources, aquatic resources, other biological resources, and water resources (SEEA-CF, 2012). However, the SEEA does not define natural capital expressly. However, in many cases the natural capital encompasses the range of natural resources ranging from ecosystems through to abiotic resources, such as minerals. In this report the main focus is on ecosystem accounting.

The aim of natural capital accounting is to show how natural resources contribute to the economy, and how the activities of the economy affect natural resources — often, in order to inform better decisions. These detailed statistics, regarding such items as inputs of water or energy, and outputs of pollution, are intended to contribute to the design of better economic management strategies overall.

'Natural capital accounting' is defined by the European Commission as a tool to measure the changes in the stock and condition of natural capital at a variety of scales and to integrate the value of ecosystem services into biodiversity and reporting systems (EC, 2016c).

¹ Shadow value: that is, a value for something not ordinarily quantifiable as having a market price.

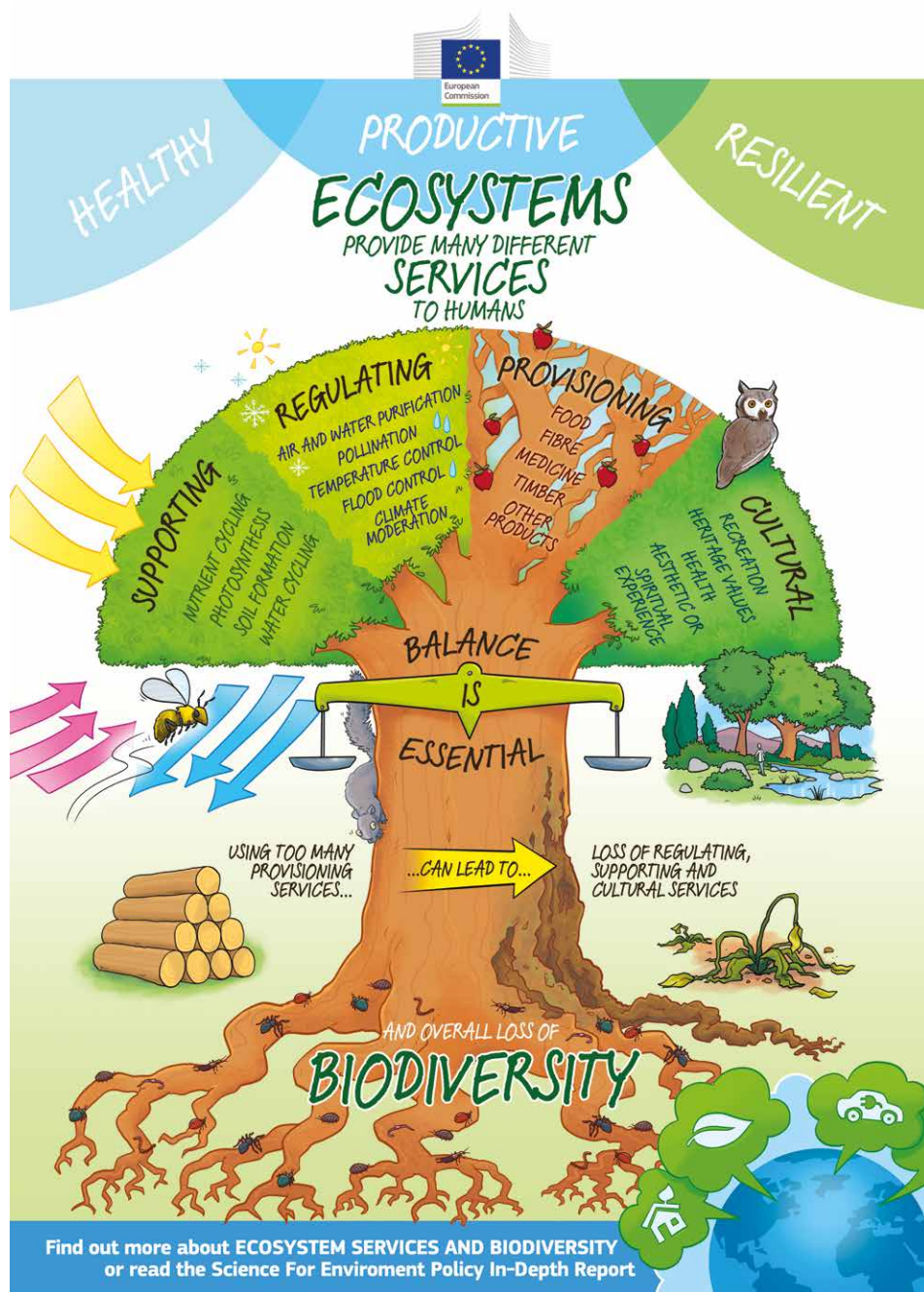

Figure 3: Ecosystem services and biodiversity infographic, Science for Environment Policy, 2016. Available at: http://ec.europa.eu/environment/integration/research/newsalert/multimedia/ecosystem_services.htm

where both have a key, intersecting role in the other, although they are not the same. Biodiversity underpins all ecosystem services and can also be valued analytically (Mace *et al.*, 2012).

Natural capital accounting, enables ecosystem assets (i.e. the 'stocks') as well as the services (i.e. the 'flows') to be defined in relation to one another as well as to other economic, social or environmental information. . For example, a forest ecosystem (the asset), by way of its trees (the stock) helps provide fresh air and can help defend against flooding, as well as being a source of timber (the services). As long as a forest is sustainably maintained, the supply of fresh air, flood defences and the stock of timber can remain consistent, and the 'balance sheet' remains healthy. If the forest is over-harvested, the

'debits' cover not only loss of the forest itself but all of the other services that the ecosystem provides (see **Figure 3**).

The definition goes beyond the commodities that can be sourced from nature, such as timber, water or minerals, to encompass whole geo-ecosystems and the services they provide.

A fundamental aspect of natural capital accounting is the recognition that a single ecosystem will generate a range of ecosystem services and, therefore, contribute a number of benefits to humans and economic activity. Biodiversity and ecosystem services have a multi-layered relationship,

The aim of accounting is not simply to create a static record or a snapshot in time, as a research study might, but to produce ongoing accounts and balance sheets in the same way as national accounts. Taking the SNA as a guide, natural capital accounts could eventually produce data that are useful to inform comparative analysis, decision- and policymaking. In this way, it

may become easier to take stock of the natural assets, how they are changing and how they can be used sustainably or even enhanced.

i.iii Current international policy context

In 2011, the EU adopted the Biodiversity Strategy which aims to halt the loss of biodiversity and ecosystem services in the EU and help stop global biodiversity loss by 2020.

The Strategy aims to ensure “no net loss of biodiversity and ecosystem services” (Action 7, Target 2). Particularly relevant, is the requirement to improve knowledge of ecosystems and their services in the EU:

“Member States, with the assistance of the Commission, will map and assess the state of ecosystems and their services in their national territory by 2014, assess the economic value of such services, and promote the integration of these values into accounting and reporting systems at EU and national level by 2020.” (Action 5, Target 2)

This is in line with the Convention on Biological Diversity which is designed to address international conservation and sustainability concerns, such as mass extinctions and ecosystem degradation. The Convention outlines the Aichi Biodiversity Targets for 2011–2020, which include the goal of mainstreaming biodiversity across government and society. By 2020, the aim is that biodiversity values have been integrated into national and local development and poverty reduction strategies and planning processes and are being incorporated into national accounting, as appropriate, and reporting systems.

The 7th Environmental Action Programme of the European Union (which is binding upon Member States via [Decision No 1386/2013/EU](#), and which entered into force in January 2014), sets out a vision of what it wants the European Union to look like by 2050.

Developing and applying indicators to monitor the sustainability of progress at various scales is essential in this context. The 7th EAP indeed highlights the need to continue work to integrate economic indicators with environmental and social indicators, including by means of natural capital accounting.

In 2050, we live well, within the planet's ecological limits. Our prosperity and healthy environment stem from an innovative, circular economy where nothing is wasted and where natural resources are managed sustainably, and biodiversity is protected, valued and restored in ways that enhance our society's resilience. Our low-carbon growth has long been decoupled from resource use, setting the pace for a safe and sustainable global society.
7th EAP

Clear among its three objectives for achieving the vision is an explicit requirement to “protect, conserve and enhance the Union’s natural capital”: stepping up efforts via a common strategy and shared responsibilities.

More recently, there is the [Paris Agreement](#) (2016), which, in Article 5(1), states that parties should take action to conserve and enhance sinks and reservoirs of greenhouse gases, including forests — and provides that Parties shall engage in adaptation planning, including “Building the resilience of socioeconomic and ecological systems, including through economic diversification and sustainable management of natural resources” (Article 7(9e)).

However, many existing requirements in policies or legislation are loose or voluntary and there is no comprehensive framework to ensure no net loss of natural capital.

i.iv Business context

There is also a growing understanding and discussion of the value of accounting for natural capital for businesses, although this report will focus on governmental or government supported literature. The EC DG Environment has set up the Business @ Biodiversity (B@B) Platform, which works with business to develop tools and approaches that integrate

natural capital and biodiversity into business practice. In 2016 B@B produced a high-level review of the key linkages between [Natural Capital Accounting and 'Net Impact'](#) (i.e. the aggregated environmental effects caused by business activities).

The Natural Capital Coalition’s Protocol also focuses on business-level accounting, building on existing tools to propose a common framework for natural capital assessment, helping businesses to measure, value and integrate natural capital into existing processes. In their [Primer for business](#) they outline the protocol for generating trusted, credible, and actionable information for business managers to inform decisions.

The UK’s Chartered Institute of Management Accountants has asserted that natural capital will become as prominent a business concern in the 21st Century as the provision of adequate financial capital was in the 20th Century (Rapacioli, 2014). However, a recent rapid overview of the state of private investment in natural capital in the UK found that there are still very few examples of natural capital projects where a financial return on investment is proven (DEFRA, 2017), and therefore viable on the market. The review also found that natural capital investment — and natural capital — was a term not yet sufficiently embedded to report on activities in a coherent fashion (DEFRA, 2017).

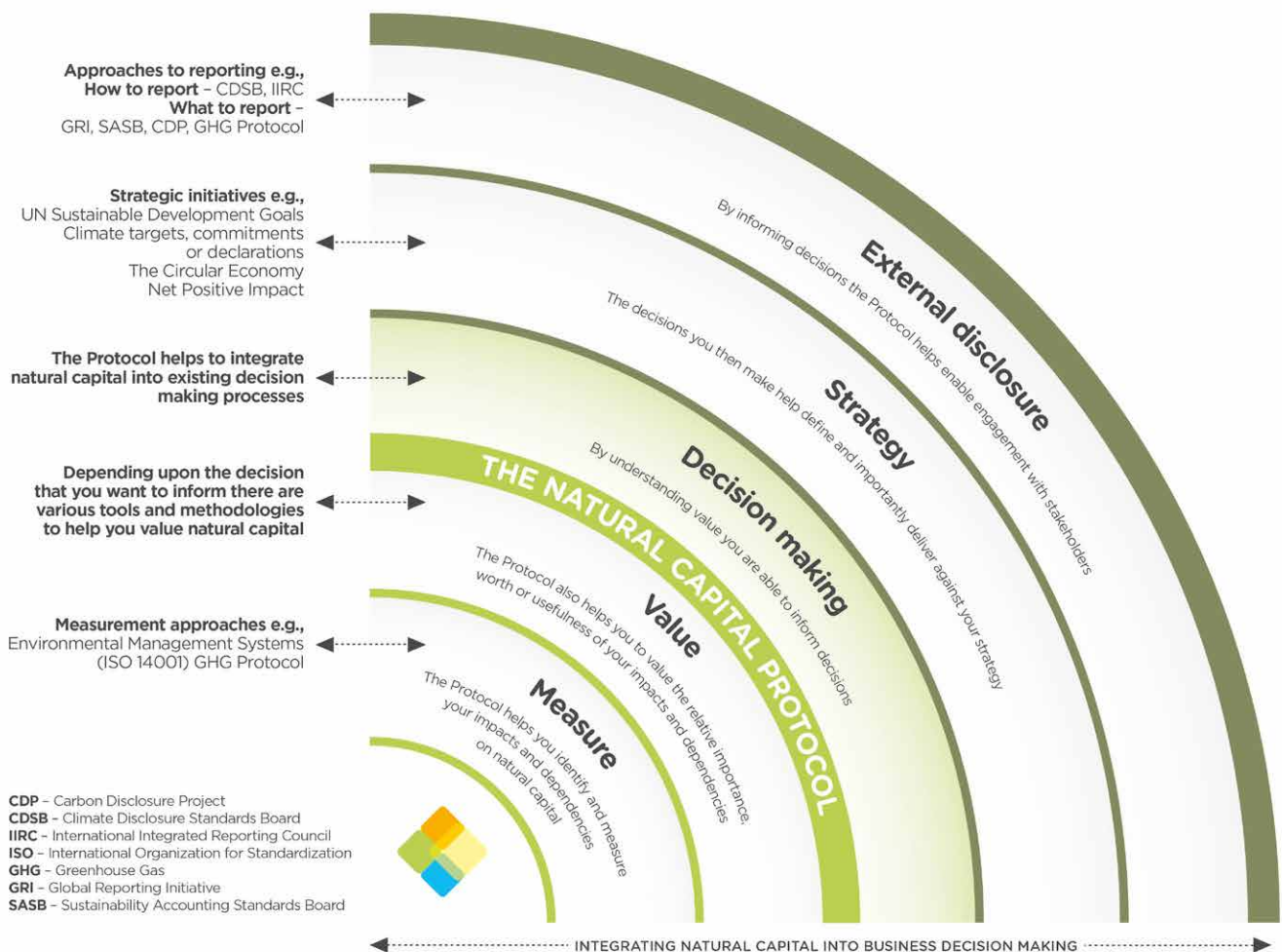

This landscape is not exhaustive. The Natural Capital Coalition will continue to explore the landscape as it evolves.

Figure 4: Natural Capital Protocol. Source: Natural Capital Coalition, 2016. Available at: <http://www.naturalcapitalcoalition.org/protocol>

Potted history of natural capital accounting

1930s

The Great Depression highlighted the fact that policy-makers had only limited and fragmented information about national income and output with which to guide the economy. In response, the US commissioned a first set of national economic accounts (Obst and Vardon, 2014).

1950s

The information generated by national accounts became so indispensable to policy-makers that international standards for measuring economic activity were developed by the UN. Since the 1950s, most countries have followed the UN System of National Accounts (SNA). Using this framework, member states of the UN submit annual data on national income, savings and some elements of wealth. The data form the basis for economic analysis and policy formation.

All countries measure national income but only a small number compile national balance sheets — or wealth accounts — and even fewer include natural capital.

1973

The first explicit reference to natural capital is in *Small Is Beautiful*, a book by British economist E. F. Schumacher. He argued that irreplaceable natural capital stocks make up the larger part of all capital, and that modern economists erroneously treat their depletion as income. He identified two types of natural capital. The first was fossil fuels, which were rapidly being exhausted. The second was the ability of natural systems to regenerate themselves, threatened by novel chemicals against which nature had no defences.

Although they did not use the specific phrase natural capital, other researchers, including Herman Daly and Nicholas Georgescu-Roegen were simultaneously stressing that the goods and services provided by nature are essential, non-substitutable factors of production, and that the finite supply of these resources limits continued economic growth. (Farley, 2012)

1980s

During the 1980s and 90s, several countries started compiling environmental accounts as satellites to the SNA. For example, in response to frequent and more intense droughts, Australia explored how scarce water resources are being used. After debates and experiments over a methodology to compile accounts in the late 1990s, the government began accounting for how much water is used by different sectors — agriculture, industry, and households — and the price these sectors were paying for consuming it.

When drought struck again, this information helped to ensure that the most critical and efficient users got water. Australia has now expanded its suite of natural capital accounts to include energy, minerals, land, and environmental protection expenditure.

1990s

In the 1990s, the World Bank began constructing a global database for ‘comprehensive wealth accounts’. The natural capital component includes agricultural land, forest land, protected areas and subsoil assets. If wealth is decreasing, for example from depletion or degradation of natural capital, then a country will not be able to sustain its current level of income.

Adjusted Net Savings (ANS) is a related indicator developed by the World Bank which measures whether a country is building its wealth or running it down. ANS is intended to be used alongside traditional macroeconomic indicators such as GDP: GDP indicates whether an economy is growing while ANS indicates whether that growth is sustainable (Nunes *et al.*, 2014).

1992

At the 1992 Earth Summit held in Rio de Janeiro, the governments of 178 countries agree to adopt Agenda 21, an action plan for sustainable development. The agreed text recognises the importance of measuring natural capital:

“A first step towards the integration of sustainability into economic management is the establishment of better measurement of the crucial role of the environment as a source of natural capital and as a sink of by-products generated during the production of man-made capital and other human activities” (Chapter 8.41 of Agenda 21, ‘Integrating Environment and Develop in Decision-Making’, UN Conference on Environment and Development, Rio de Janeiro, 1992).

1993

The Convention on Biological Diversity (CBD) was opened for signature at the Earth Summit and entered into force in December 1993. There are 196 parties and 168 signatories. As of 2017, the US has signed but not ratified it.

The Convention recognised for the first time in international law that the conservation of biological diversity is “a common concern of humankind” and is an integral part of development. It links conservation efforts to the economic goal of using biological resources sustainably.

The three main goals are:

- conservation of biological diversity;
- sustainable use of its components;
- fair and equitable sharing of benefits arising from genetic resources.

The compilation of satellite accounts leads to the development of the first handbook for a System of Environmental Economic Accounting, published in 1993. From a simplistic anthropocentric point of view, the natural environment exists to be exploited and it is of no interest whether natural balances are disturbed. However, the handbook describes how excessive exploitation has become counter-productive.

The SEEA 1993 discusses accounting for environmental services as one of several possible extensions to the core system of traditional national accounts. To describe the interrelationships between

the environment and the economy requires data that is not available in value terms. Different concepts and valuation methods should be tested, with the object of monitoring environmental changes caused by economic activities.

Three types of services are distinguished: disposal services, productive services of land (e.g. use of soil for agricultural purposes), and consumer services (e.g. amenity services).

However, the description of these services is limited to a recording of their decrease (Edens and Hein, 2013). The system proposes to subtract restoration costs from GDP. The first SEEA was criticized for not accounting for the positive non-market outputs of natural resources (termed environmental quality services), which could add to GDP (Peskin and Delos Angeles, 2001).

1994

In 1994, the European Commission issued a [Communication COM 94/670 on directions for green national accounting](#), to help the integration of environmental and economic information systems. These were based on satellite accounts to the SNA (COM, 1994). It stated that what is needed as a first step in establishing a European framework for ‘green accounting’ is “a harmonised European system of integrated economic and environmental indicators and accounts which addresses the problems of the various economic sectors and policy fields at various levels and which will allow for comparison between Member States”.

In the same year, an informal group of experts, primarily from national statistics agencies, met for the first time to share their experiences of developing and implementing environmental accounts linked to the System of National Accounts: the London Group on Environmental Accounting.

Their aim was to develop a way to construct accounts relevant to the environment that could be integrated into national accounts. In this way, finance ministers and policy makers would be able to make decisions that impact on the environment in a way that

more accurately measures the value of a country's environmental assets. They played a leading role in developing the SEEA. The London Group continues to meet annually to compare and advance the methodologies developed.

1997

A *Nature* magazine article estimates the annual value of global ecological benefits at \$33 trillion, a number nearly twice the gross global product at the time (Constanza *et al.*, 1997).

2000

UN Secretary-General Kofi Annan calls for a global assessment of the ways in which ecosystem change could affect human well-being. The Millennium Ecosystem Assessment (MA) was published in 2005. It included the first comprehensive audit of the status of the Earth's natural capital and found that 60% of a group of 24 ecosystem services examined are being degraded.

The main findings:

Over the past 50 years, humans have changed ecosystems more rapidly and extensively than in any comparable period in human history, largely to meet rapidly growing demands for food, fresh water, timber, fibre and fuel. This has resulted in a substantial and largely irreversible loss in the diversity of life on Earth.

The changes that have been made to ecosystems have contributed to substantial net gains in human well-being and economic development, but these gains have been achieved at growing costs in the form of the degradation of many ecosystem services, increased risks of nonlinear changes, and the exacerbation of poverty for some groups of people. These problems, unless addressed, will substantially diminish the benefits that future generations obtain from ecosystems.

The degradation of ecosystem services could grow significantly worse during the first half of this century and is a barrier to achieving the Millennium Development Goals.

The challenge of reversing the degradation of ecosystem while meeting increasing demands for services can be partially met under some scenarios considered by the MA, but will involve significant changes in policies, institutions and practices that are not currently under way. Many options exist to conserve or enhance specific ecosystem services in ways that reduce negative trade-offs or that provide positive synergies with other ecosystem services.

The bottom line of the MA findings is that human actions are depleting Earth's natural capital, putting such strain on the environment that the ability of the planet's ecosystems to sustain future generations can no longer be taken for granted. At the same time, the assessment shows that with appropriate actions it is possible to reverse the degradation of many ecosystem services over the next 50 years, but the changes in policy and practice required are substantial and not currently underway. (MA, 2005).

2002

Eurostat, the European statistical agency, makes an important contribution to the field by discussing the incorporation of environmental and recreational functions in a forest accounts framework (Edens, 2013). The EU's forests and other wooded land cover approximately the same proportion of land area as that used for agriculture (Eurostat, 2015).

The framework, called Integrated Environmental and Economic Accounting for Forests (IEEAF), was piloted from 2004. Accounts included were monetary and physical balance sheets for forest land and standing timber, economic accounts for forestry and logging, monetary and physical supply-use tables for wood products and material balances. Non-wood products and non-timber functions of forests were also addressed.

From late 2015, a pilot for a new set of European Forest Accounts (EFA) collection began and will replace the IEEAF.

2003

The successor framework of the SEEA 1993, the SEEA 2003 included a separate section on land and ecosystem accounts, but limited the description to accounts in physical terms. On the valuation of depletion and degradation, the SEEA 2003 refrained from providing unique recommendations, and instead resorted to providing multiple options, which is one of the reasons why it fell short of being a statistical standard.

The SEEA 2003 also does not contain a systematic discussion of ecosystem services. Many countries — especially in the European context — hereafter shifted their focus from accounting in monetary terms towards compiling physical accounts, given the difficulties around valuation and double counting. Several country-level studies, for instance in Germany and Sweden, estimated green GDP types of measure. They achieved mixed results in producing monetary estimates of changes in environmental variables (Edens and Hein, 2013).

2005

UN Committee of Experts on Environmental-Economic Accounting (UNCEEAA) was established by the UN Statistical Commission to:

- Mainstream environmental-economic accounts and related statistics
- Elevate the SEEA to an international standard
- Advance the implementation of the SEEA in countries around the world and promote its use in support of government policy.

Members of the group include national statistical offices, Eurostat, the International Monetary Fund (IMF), the European Environment Agency (EEA) and the Organisation for Economic Cooperation and Development (OECD).

Costa Rica and Papua New Guinea, on behalf of the Coalition for Rainforest Nations, submit the document 'Reducing Emissions from Deforestation in Developing Countries: Approaches to Stimulate Action' (REDD) to the United Nations Framework

Convention on Climate Change (UNFCCC). REDD is envisaged as a giant "payment for ecosystem services" scheme to which 70 developing countries could be eligible with an ambition to halve deforestation by 2020 (The Economist, 2010).

The FAO estimated in 2005 that deforestation was occurring at 13 million hectares per year, mainly through the conversion of forests to agricultural land. Meanwhile, the International Panel on Climate Change (IPCC) Working Group III concludes that forest-related mitigation activities can considerably reduce emissions and increase CO₂ removals by sinks at low costs (Metz *et al.*, 2007).

2007

The European Commission, the European Parliament, the Club of Rome, the OECD and the WWF hosted the high-level conference Beyond GDP. Subsequently, the European Commission launched the Communication COM(2009) 433 [GDP and Beyond: Measuring Progress in a Changing World](#). It recommended a number of actions to help more inclusive indicators to be developed and to create a more reliable knowledge base for policy-making and public debate.

Following a meeting of G8+5 environment ministers, a global study was launched to draw attention to the global economic benefits of biodiversity and the costs of biodiversity loss and ecosystem degradation. [The Economics of Ecosystems and Biodiversity \(TEEB\)](#) initiative, aims to mainstream the values of biodiversity and ecosystem services into decision-making at all levels.

The study follows a tiered approach to valuation guided by three core principles:

- Recognising value in ecosystems, landscapes, species and other aspects of biodiversity.
- Demonstrating value in economic terms. For example, calculating the costs and benefits of conserving the ecosystem services provided by wetlands in controlling floods compared to the costs of building flood defences.

- Capturing value through incentives and price signals, for example payments for ecosystem services, reforming subsidies that harm the environment or introducing tax breaks for conservation.

One limitation of the approach was in how production boundaries were drawn for accounting purposes. For example, the ecosystem service boundary for crops was equated to the crops themselves. However, ecosystems provide services beyond the removal of biotic resources. The connection between the production boundary and the valuation of assets is important for national accounting since it permits measures of production, income, assets and degradation to be aligned (Obst *et. al.*, 2016).

In 2012, TEEB for Business was launched and became the Natural Capital Coalition in 2014.

2010

The ability of developing countries to build their natural capital account capacities is being improved through [Wealth Accounting and the Valuation of Ecosystem Services \(WAVES\)](#). WAVES is a global partnership that was inaugurated in October 2010 by the World Bank. It aims to promote sustainable development by encouraging the inclusion of natural capital measurements in national accounts.

With extensive support from WAVES, Botswana, Colombia, Costa Rica, Madagascar and the Philippines embarked on programs for natural capital accounting, endorsed at the highest level of government. These five countries established steering committees, identified policy priorities and designed work plans that include compiling accounts for natural resources like forests, water and minerals and experimental accounts for ecosystems like watersheds and mangroves.

Guatemala, Indonesia and Rwanda joined in 2013 and WAVES plans to increase the number of participating countries. In developing countries, natural capital

is a particularly critical asset for supporting human wellbeing and sustainable economic growth because it makes up around 36% of total wealth.

As of 2017, 65 countries have signed the WAVES partnership communique on natural capital accounting, which invites governments, financial institutions and other international organisations to:

- develop institutional arrangements to strengthen the implementation of natural capital accounting;
- develop science-based methodologies on an experimental basis for ecosystem accounting as a complement to GDP and corporate performance;
- pilot and demonstrate the economic, social and environmental aspects of scaled up and integrated approaches to natural capital accounting.

2011

The first formal EU rules on environmental accounting were established with the [Regulation on European Environmental Economic Accounts \(EU No 691/2011\)](#). It requires Member States to regularly report on three areas to the European Statistical Office (Eurostat). They are air emission accounts, accounts on environmental taxes and economy-wide material flow accounts. The Regulation establishes that more modules can be added in the future to respond to key policy needs.

The Strategic Plan for Biodiversity 2011–2020 consists of 20 new biodiversity targets for 2020, named Aichi Targets. The second of the ‘Aichi Biodiversity Targets’ is: “By 2020, at the latest, biodiversity values have been integrated into national and local development and poverty reduction strategies and planning processes and are being incorporated into national accounting, as appropriate, and reporting systems.”

2012

An update on the SEEA is adopted by the UN Statistical Commission as an international statistical standard, the SEEA Central Framework. At the

same time, the SEEA 2012 Experimental Ecosystem Accounting (SEEA-EEA) guidelines are completed.

The SEEA-EEA provides a starting point for developing ecosystem accounting at national and sub-national levels. The guidelines detail a common set of terms, concepts, accounting principles and classifications and provide an accounting structure to monitor ecosystem services and ecosystem condition in both physical and monetary terms. Together with the central framework, they provide the potential to describe the relationship between the environment and economic and other human activity in a comprehensive way.

In June 2012, the Rio+20 conference “marked a watershed in the world wide interest on Natural Capital Accounting.” (WAVES, 2013). The World Bank started the 50:50 initiative inviting the public and private sectors to join forces and take collective action to support natural capital accounting. By the time of the conference, 62 countries, 90 corporations and 17 civil society members had joined the campaign.

Prior to the conference, The Natural Capital Declaration (NCD) was announced. This is a declaration from the financial sector to embed environmental, social and governance (ESG) considerations in management and investment activities. It has been signed by the CEOs of more than 40 financial institutions, demonstrating their commitment to integrating natural capital considerations into private sector reporting, accounting and decision-making by 2020.

2013

The first priority of 7th EU Environmental Action Programme, designed to be the guiding European environment policy until 2020, is to protect, conserve and enhance the Union’s natural capital.

The 7th EAP acknowledges that economic prosperity and well-being is underpinned by its natural capital, i.e. its biodiversity. Ecosystems provide essential goods and services, from fertile soil and multi-functional forests to productive land and seas, from good quality

fresh water and clean air to pollination and climate regulation and protection against natural disasters. It also acknowledges that work to develop a system of environmental accounts, including physical and monetary accounts for natural capital and ecosystem services, will need to be stepped up.

One of the actions identified is: “Developing and applying alternative indicators that complement and go beyond GDP to monitor how sustainable our progress is and continuing work to integrate economic indicators with environmental and social indicators, including natural capital accounting”.

The Common International Classification of Ecosystem Services (CICES) sets out a potential standard to be followed. It is based on the well-established split into Provisioning, Regulating and Cultural Services. However, it is deemed to be rather cumbersome to apply in practice and some of the definitions could be described in more accessible terms. It therefore works better as a checklist than as a standard to be followed in all its detail (Defra, 2014).

The inaugural World Forum on Natural Capital took place in 2013. The organisers claimed that ‘a revolution is taking place in how businesses and governments account for natural capital’, and that ‘there has never been a better time for senior decision makers to exercise leadership for the benefit of business and the planet’.

2014

Robert Constanza, the author of a 1997 paper in *Nature*, undertook another assessment of global ecosystem services with a qualified group of co-authors. More detailed 2011 data took the aggregate global ecosystem services provisioning estimate to between \$125–145 trillion a year. The same researchers also estimated that between \$4.3 to \$20.2 trillion a year of losses are accrued to ecosystem services due to land use change.

Several amendments to the [Regulation on European Environmental Economic Accounts \(EU\)691/2011](#) are adopted. The amendments add new modules to Regulation (EU) 691/2011: on environmental expenditure, energy flow accounts and the environmental goods and services sector.

2015

The [Natural Capital Coalition](#) welcomed 40 leading businesses to develop the [Natural Capital Protocol](#). The aim of the Protocol is to define for businesses a way to measure and value their impacts and relationships with nature.

Ten businesses tested it against a range of specific business applications such as water use and supply chain management. It was launched in July 2016 and is described in more detail in the next Section.

At the launch, it was described by one of the company directors involved as “a momentous step forward” for the practice of natural capital accounting (quoted in Greenbiz., 2016).

2016

On 1 January, a set of 17 new Sustainable Development Goals came into force, building on the success of the Millennium development goals. Goal 14 is to “Conserve and sustainably use the oceans, seas and marine resources for sustainable development”. Goal 15 is to “Protect, restore and promote sustainable use of terrestrial ecosystems, sustainably manage forests, combat desertification, and halt and reverse land degradation and halt biodiversity loss”.

They are not legally binding, but governments of all countries are expected to establish national frameworks to help achieve them and to review progress. Natural capital accounting can help delivery



Person Walking on Log in Forest. Jon Flobrant on Unsplash. Public domain, 2014.

against the goals by making explicit the links between the economy and the environment and by establishing the best ways to measure progress.

For example, target 15.9 is that by 2020, signatories will integrate ecosystem and biodiversity values into national and local planning, development processes, poverty reduction strategies and accounts. Target 17.19 is that by 2030 signatories will build on existing initiatives to develop measurements of progress on sustainable development that complement gross domestic product, and support statistical capacity-building in developing countries (Sustainable Development Goals, 2016).

In June the World Bank announced the implementation of the natural capital accounting programmes that had been developed in the five core WAVES countries, Botswana, Colombia, Costa Rica, Madagascar and the Philippines. (See Section 4 for further detail).

1. Methods for natural capital accounting

Over the past 20 years, important advances have been made in making the case for measuring natural capital and ecosystem services. Over the years, different protocols have been suggested but it has also been recognised that it is important that countries agree on an international standard, since ecosystem assets and services do not respect country borders. Such a standard would make within-country and between-country comparisons viable; however, in terms of developing the methods required, it is still a work in progress. In 2012 the United Nations Statistics Commission (UNSC) published detailed methodological guidance on how to prepare environmental-economic accounts, alongside information on assessing ecosystem condition and ecosystem services. The framework aims to instigate an international standard for governments to organise and integrate environmental data into national accounts.

This Section introduces the SEEA framework and guidelines, accounting terms used in ecosystem accounting, and provides a summary outline of the accounting methods suggested

1.1 The UN system for environmental accounting: SNA and SEEA

The international System of National Accounts (SNA) provides a standard for how to compile measures of economic activity in general. The system enables countries to show how income from produced capital flows between consumers, businesses, governments, NGOs and countries — and what the balance of flows and stocks looks like at a particular point in time. Countries that are represented by the UN are required to report via the SNA mechanism once a year.

The UN's System of Environmental-Economic Accounting (SEEA) provides a global standard for linking environmental and economic accounting. Its consistency is linked to the fact that the SEEA Framework is linked with the SNA, which also distinguishes it from other approaches to ecosystem valuation (Hein *et al.*, 2015). SEEA has been developed in order to understand the contribution of ecosystems to economic activity and household consumption of resources (SEEA-CF 2012). The framework covers

the stocks and flows that are relevant to environmental and economic issues. It does not expressly define natural capital, but rather defines assets as 'individual resources' or 'combinatorial assets' such as ecosystems.

Environmental assets are considered both in physical and monetary terms for mineral and energy resources, land, soil, timber, aquatic resources, water resources and other biological resources. Accounts for physical flows are provided for energy, water, materials, air emissions, waste water and solid waste (ten Brink *et al.*, 2015). This information can also be used to indicate the monetary value of ecosystems; monitor efforts to improve sustainability and understand what resources are being used; and identify ecosystems or ecosystem services threatened by overexploitation and support resource and land management planning.

The SEEA system is outlined in three volumes: the SEEA Central Framework (SEEA-CF), The SEEA Experimental Ecosystem Accounting (SEEA-EEA) and Applications and Extensions of SEEA. The SEEA CF, has been developed to align with the UN's System of National Accounting (SNA) and provides an international standard for environmental-economic accounting (Edens and Hein, 2013). The SEEA-CF provides information on key factors that influence ecosystems and ecosystem services including flows in physical terms of energy, water, air emissions and waste water. SEEA CF also details how to account for different resources (or stocks of environmental assets) including timber, water and carbon in both physical and monetary terms. Activity accounts are also provided to show expenditure on areas such as environmental protection, environmental goods, services, taxes and subsidies (SEEA-CF, 2012).

The SEEA Experimental Ecosystem Accounting (SEEA-EEA) complements the Central Framework and is primarily concerned with ecosystems using biophysical data. SEEA-EEA covers accounting for ecosystem services (flows) and assets (stocks) in physical terms and provides more detail for carbon, water and biodiversity accounts to provide a general indication of the state of an ecosystem and the services it provides. The SEEA EA provides an overview of the methods that can be used for environmental accounting but is still at an experimental level so does not provide

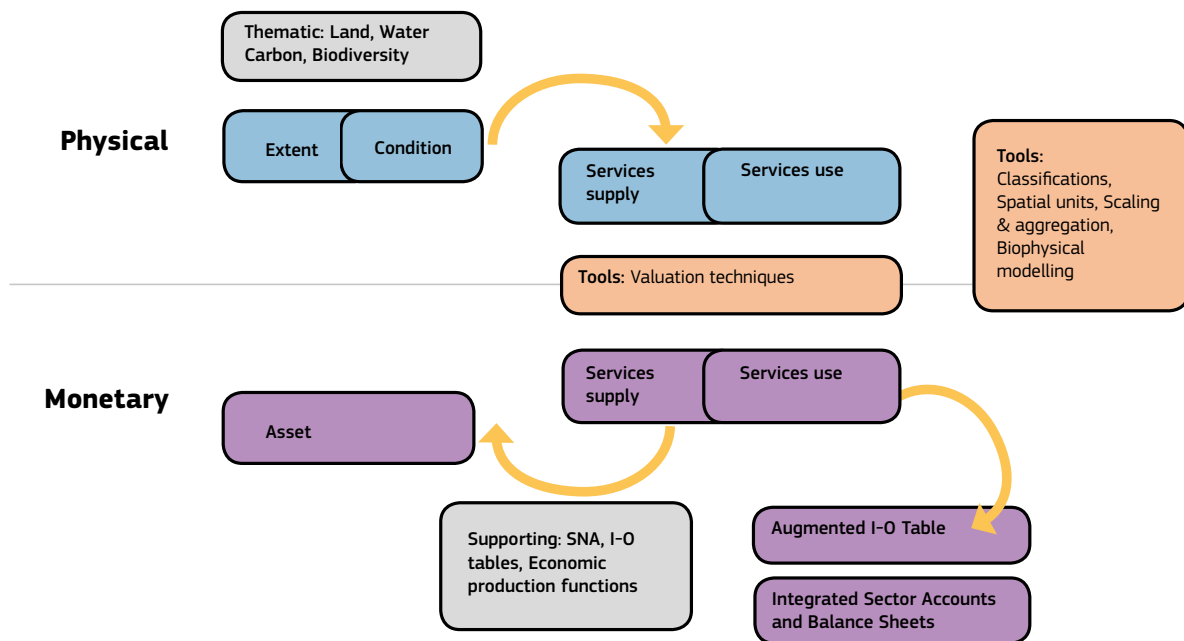

Figure 5: Eurostat components of Ecosystem Accounting. Source: Radermacher, 2015.

an international agreed standard for environmental accounting of ecosystem services (ten Brink *et al.* 2015). Another publication — Applications and Extensions of SEEA — is a guide to the use of SEEA data in policymaking and research (SEEA-CF 2012). The UN Committee of Experts on Environmental-Economic Accounting plans to work on incorporating lessons from testing experiences over the next few years, and expects release a finalised revised version of the SEEA-EEA in 2020 (UNSTAT, 2016).

The SEEA-EEA measures how different ecosystem assets interact to provide a range of ecosystem services. There are a range of scales addressed — from specific types of land cover, such as forests, to larger integrated systems like watersheds. Three categories of ecosystem services have emerged from a project to develop a Common International Classification for Ecosystem Services (CICES). These three categories are also used in the SEEA-EEA:

Provisioning services. Products obtained from ecosystems, such as food or timber.

Regulating services. The benefits obtained from the regulation of ecosystems, including services such as purification of water, flood control, or regulation of the climate via carbon sequestration.

Cultural services. The benefits people obtain from ecosystems through spiritual enrichment, cognitive development, reflection, recreation, and aesthetic experiences.

The Millennium Ecosystem Assessment and The Economics of Ecosystems and Biodiversity study (TEEB) also define supporting services, such as nutrient cycling and soil formation. These are needed to support all the other services; they do not provide a direct service to humans but are absolutely crucial for other flows of services, with more direct benefits to humans. In the SEEA-EEA, however, supporting services are classed as intra- or inter-ecosystem flows, and are only accounted for in terms of ecosystem quality/condition at a certain point — not as flows themselves.

2. Measuring ecosystem services biophysically

Ecosystem assets (or stocks) and services (flows) are measured in both biophysical and monetary terms. This Section focuses on their biophysical measurement (for economic measurement, see Section 3), with reference to the SEEA-EEA's guidelines for measurement.

Biophysical data can be used to track changes in ecosystems and link those changes to economic and other human activity (UN, 2014). http://ec.europa.eu/environment/nature/knowledge/ecosystem_assessment/pdf/3rdMAESReport_Condition.pdf

Ecosystem assets, such as wetlands, can be physically measured in units such as hectares or kilograms, to show their extent or spatial area. They can also be measured in terms of their condition and expected flows of ecosystem services provided by the assets. Under the SEEA-EEA, condition is measured through indicators, such as the presence of a particular species, biodiversity or habitat status. Different ecosystems can be represented by different indicators.

Ecosystem services are measured as a rate, for example, tonnes of CO₂ stored and released by one unit of forested land (as an example of the flow of a regulating service), or hectares of parkland in a unit of urban area (as an example of the flow of a cultural service) (UN, 2014). Estimations of the expected flows of ecosystem services will need to use a set of assumptions on the expected future use of ecosystems.

Estimates of extraction and future regeneration of resources can also be included. This can also help assess and manage trade-offs, such as those between consumption and resource protection, or the consequences of land use change, or between policies to encourage provision or regulating services. Comparison with ecosystem service flows can also show when the exploitation of an ecosystem is greater than the ability of the ecosystem to recover. For example, if a forest is completely cleared without regeneration, timber provision will decline over time. Whereas when a resource is being used sustainably the ecosystem service flow will continue into the future.

Natural capital accounts will benefit if they use spatial measurements as these can lead to maps that visualise the state of ecosystems or the flows of ecosystem services they provide (ten Brink *et al.*, 2015). Maps can provide very valuable information which can be used to: set priorities, identify at a glance where intervention is most needed, identify problems in relation to synergies and trade-offs between services provided by stocks (e.g. comparing ecosystem services provided by different land uses for a particular ecosystem type), and also act as stakeholder communication tools (MAES <http://biodiversity.europa.eu/maes> and OPERAS).

Data on stocks and flows can be compiled into accounting tables (e.g. **Figure 7**) The main objective of these tables is to allow changes in stocks to be monitored, and for the influence of these changes on the delivery of ecosystem services to be considered. The tables can show

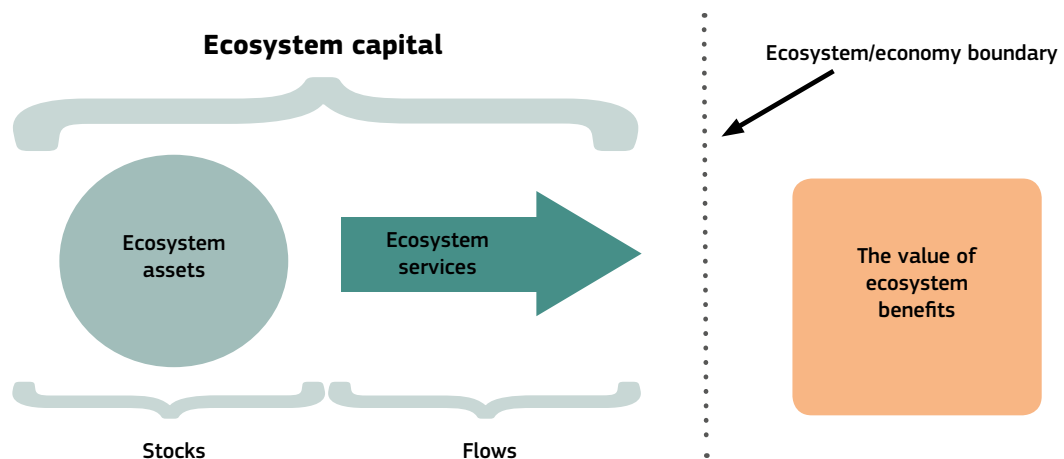

Figure 6: Natural capital and ecosystem benefits. Source: Petersen and Gocheva, 2015. Based on UNEP, 2014.

Basic form of an asset account

Opening stock of environmental assets

Additions to stock

Growth in stock
Discoveries of new stock
Upward reappraisals
Reclassifications

Total additions of stock

Reductions of stock

Extractions
Normal loss of stock
Catastrophic losses
Downward reappraisals
Reclassifications

Total additions of stock

Revaluation of stock

Closing stock of environmental assets

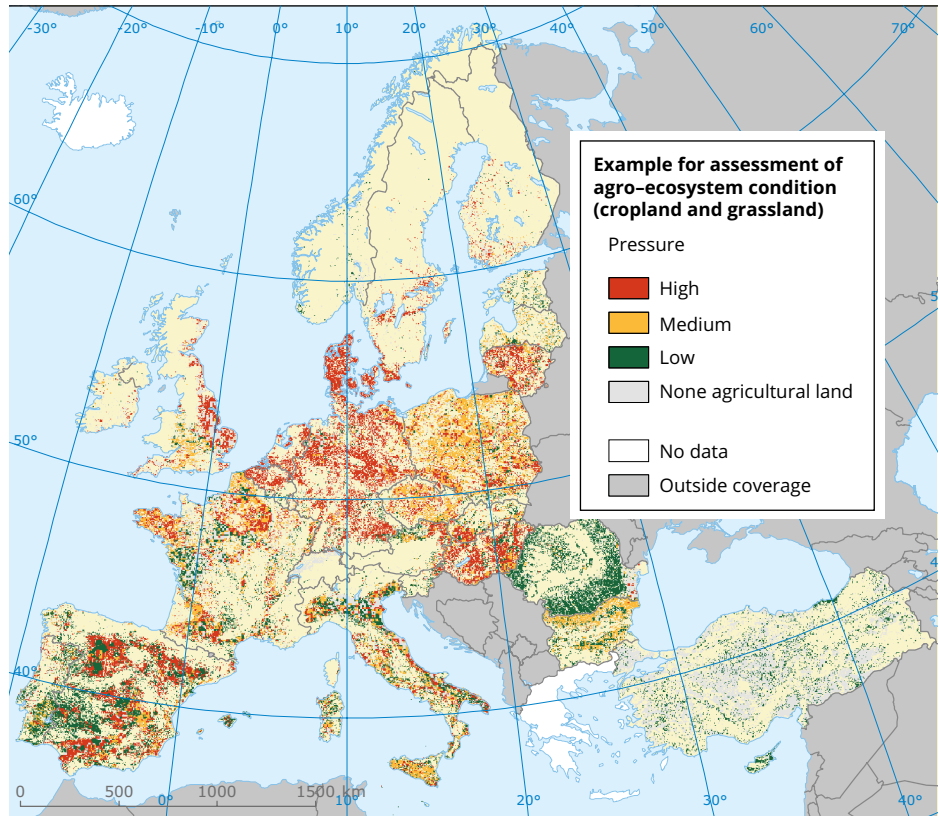
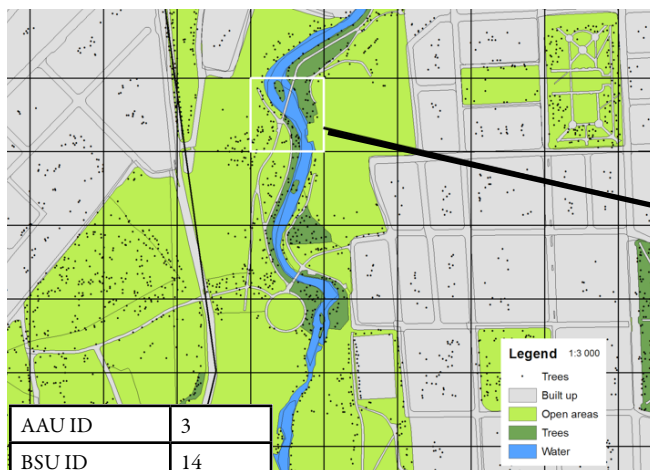
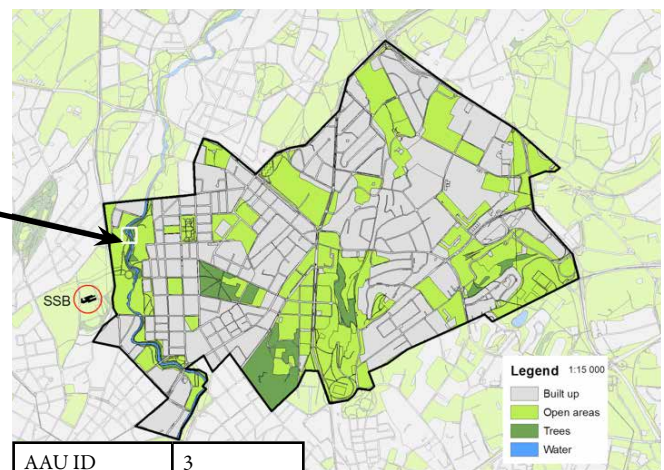

Figure 7: Potential format of an accounting table, based on SEEA-EEA. Petersen and Gocheva, 2015.

Figure 8: Aggregated assessment of cropland condition. Source: EC, 2016, from EEA, 2015. Note: Cropland condition, based on an aggregated assessment of multiple pressures and species or habitat conservation status, based on 2006 CLC data for farmed pastures and arable land with high nature value. Pastures were excluded to avoid overlap with the grassland ecosystem. This was combined with information on habitat and species condition from the Habitats Directive reporting. The units are re-scaled (classified from favourable to good) because the input consists of information in different units.



AAU ID	3
BSU ID	14
Unit area (m ²)	10000
Number of trees	85
Built up (m ²)	719.04
Open area (m ²)	5109.76
Trees (m ²)	1882.72
Water (m ²)	2288.48



AAU ID	3
Unit area (m ²)	4804452
Number of trees	13564
Built up (m ²)	2998599.36
Open area (m ²)	1534009.28
Trees (m ²)	240735.04
Water (m ²)	31088.64

Figure 9. Examples of accounts (for the Grünerløkka district of Oslo, Norway), illustrating the correspondence between a map and an account, and demonstrating ecological characteristics, such as number of trees, for each unit. Source: Garnåsjordet and Megan, 2016. Note: [URBAN-EEA, Experimental ecosystem accounting for urban ecosystems](#), is a new project set up by the [Norwegian Institute for Nature Research \(NINA\)](#), to provide decision support and demonstrate synergies between experimental ecosystem accounting and municipal level mapping of urban ecosystems and their services to the population.

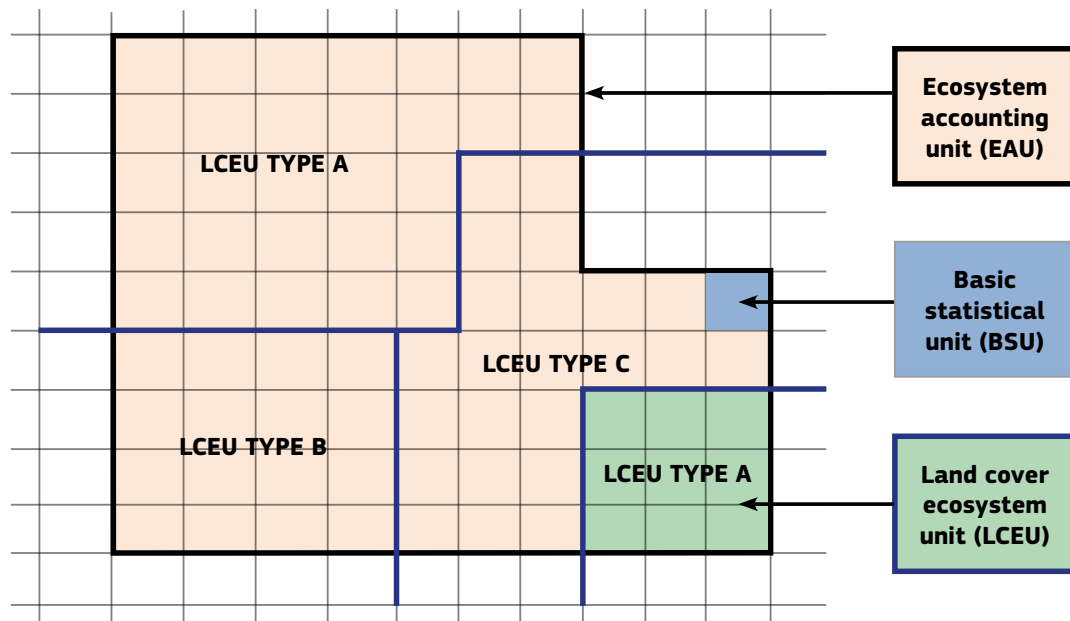

Figure 10: Stylised depiction of relationships between BSU, LCEU and EAU. Source: SEEA-EEA, 2012. Available at: https://unstats.un.org/unsd/envaccounting/eea_white_cover.pdf

supply, use and enhancement of natural resources and therefore could be used to provide a consistent approach to measuring ecosystem degradation or improvement. The spatial areas must be mutually exclusive to avoid double counting (Obst *et al.*, 2016).

The SEEA-EEA proposes (but does not prescribe) three different, but related, types of statistical unit, which are: basic spatial units (BSU), land cover/ecosystem functional units (LCEU) and ecosystem accounting units (EAU) (Figure 10).

BSUs are small spatial areas which can be used to assess local variation in flows, and so may be useful for assessing the effects of local policies (Remme, Schröter and Hein, 2014). LCEUs are larger than a BSU and represents a particular type of ecosystem. Examples of LCEU could include pastures, natural grassland and forest tree cover. EAUs are the largest spatial unit, made up of BSUs. Data from all the BSUs in an EAU can be combined to provide overall figures for the EAU. A relatively large area, such as an administrative area or a large-scale natural feature. Examples of EAUs are national parks, city districts and river basins.

2.1 Biophysical measurement in action: Limburg (Netherlands) case study

A study from the Netherlands (Remme, Schröter and Hein, 2014) provides a worked-through example of how a biophysical assessment for natural capital accounting could be conducted. The researchers assessed the flow of seven ecosystem services in the province of Limburg, which is approximately 2200 km² in size. They broadly worked according to the SEEA-EEA's guidelines to see if these were feasible in practice at Limburg's scale.

First, the researchers divided Limburg up according to the three types of spatial unit recommended by the SEEA-EEA:

- Administrative boundaries formed EAUs
- LCEUs were defined according to eight ecosystem types, which included pastures, urban areas and forest. These categories did not come from the SEEA-EEA, but were drawn from land cover classes of the Dutch land cover map LGN6 (Hazeu, 2009).

- Each LCEU was divided up into 25 x 25m grid cells to form BCUs

For each type of spatial unit, the researchers created a basic accounting table of ecosystem service flows. The ecosystem services were: hunting, drinking water extraction, crop production, fodder production, air quality regulation, carbon sequestration and recreational cycling, which represented a range of provisioning, regulating and cultural services.

For each service, an indicator for measuring flow was defined. For example, air quality regulation was measured in kilograms of PM10 captured by vegetation per square metre of land, and drinking water extraction was measured as cubic metres of water extracted from shallow groundwater per hectare of land in groundwater protection zones, per year. The data for these indicators came from previous studies and the researchers spatially assessed them using computer modelling.

Accounts at the level of BSUs demonstrated differences in flow at a very local scale. For example, one BSU was estimated to capture 0.6 kg of PM10 per year, whilst a neighbouring BSU captured 2.3 kg, owing to differences in characteristics.

Accounts at the level of LCEUs allowed the researchers to assess differences in flow according to ecosystem type. For example, the (mean) average amount of PM10 captured in all of Limburg's forested land was 2001 kg per km² per year, but just 535 kg/km²/yr in urban areas.

The study's authors conclude that it is indeed feasible to apply the SEEA-EEA's guidelines in the case of the Limburg province, for which rich data are available. In principle, the methods they followed would also be appropriate at the national scale, they add.

2.2 Challenges and outlook for measurement of ecosystem assets and flows

Biophysical measurement enables natural capital accounting to take stock of existing natural assets and quantify the benefits they offer to society. Spatial accounts offer a range of benefits which aid decision-making and communication. Accounting data organized by different sizes of spatial units can enable broad physical assessment of natural capital across a large area, such as a province or even country, as well as local assessment within a small area of land, such as a neighbourhood.



[Wie sjoen os Limburg is / That's how beautiful Limburg is](#). Bert Kaufman, 2012. Flickr. [CC BY-SA 2.0](#).

Table 1. An accounting table showing ecosystem flows for nine individual neighbouring BSUs in Limburg. Source: Remme, Schröter and Hein (2014).

Ecosystem service	Unit	Basic spatial unit number								
		1	2	3	4	5	6	7	8	9
Hunting	kg/yr	0.02	0.02	0.02	0.02	0.02	0.02	0.02	0.02	0.02
Drinking water extraction	m ³ /yr	58	58	58	58	58	58	58	58	58
Crop production	kg/yr	0	0	0	0	0	0	0	0	0
Fodder production	kg/yr	935	935	0	935	935	0	681	0	0
Air quality regulation	kg/yr	0.6	2.3	2.3	0.6	2.3	2.3	0.6	2.3	2.3
Carbon sequestration	kg/yr	11	11	91	11	11	91	0	0	0
Recreational cycling	trips/yr	0	4	4	0	4	4	4	1	1
Land cover	-	Grassland	Grassland	Forest	Grassland	Grassland	Forest	Cropland	Cropland	Cropland

Table 2. An accounting table showing total and mean average annual ecosystem service flows for each of the eight LCEU types in Limburg. Source: Remme, Schröter and Hein (2014).

LCEU	Ecosystem service													
	Hunting		Drinking water extraction		Crop production		Fodder production		Air quality regulation		Carbon sequestration		Recreational cycling	
	Total (kg meat)	Mean (SD) (kg meat km ⁻² yr ⁻¹)	Total (103 m ³ water)	Mean (SD) (m ³ water ha ⁻¹ yr ⁻¹)	Total (106 kg produce)	Mean (SD) (kg produce ha ⁻¹ yr ⁻¹)	Total (106 kg dm)	Mean (SD) (kg dm ha ⁻¹ yr ⁻¹)	Total (103 kg PM ₁₀)	Mean (SD) (kg PM ₁₀ km ⁻² yr ⁻¹)	Total (103 kg carbon)	Mean (SD) (103 kg C ha ⁻¹ yr ⁻¹)	Total (103 trips)	Mean (SD) (trips ha ⁻¹ yr ⁻¹)
Pasture	9100	21 (17)	7026	2389 (694)	-	-	533	12,019 (1571)	404	909 (528)	8019	0.18 (0)	1863	103 (77)
Cropland	14,732	23 (20)	11,227	2329 (744)	1868	41,804 (24,339)	251	10,894 (0)	717	956 (535)	273	0.00 (0.03)	2611	98 (72)
Forest	8100	23 (20)	3117	2119 (811)	-	-	-	-	700	2001 (1228)	50,664	1.45 (0)	1565	128 (95)
Water	-	-	478	1369 (621)	-	-	-	-	40	613 (558)	0	0.00 (0)	139	109 (91)
Urban	-	-	4071	2298 (788)	-	-	-	-	272	535 (546)	875	0.02 (0.05)	2690	70 (56)
Heath	678	32 (25)	214	1262 (614)	-	-	-	-	45	2056 (1116)	393	0.18 (0.03)	30	84 (61)
Peat	70	13 (3)	-	-	-	-	-	-	7	968 (347)	149	0.18 (0)	3	84 (43)
Other nature	1513	25 (20)	862	2248 (750)	-	-	-	-	69	1153 (705)	1056	0.20 (0)	220	127 (95)
Provincial total	34,193				1868		784		2254		61,429		9122	

However, natural capital accounting is still in an early phase of development and faces a number of challenges. For example, figuring out how to use detailed data compiled from a single study site to make estimates for a larger area or for a site that is the focus of policy decisions. There are also challenges associated with recording gross and net details and with aggregating different ecosystem services when they are recorded

using different measurement units such as tonnes of CO₂ or timber or numbers of walkers. The methods used to measure natural capital are still to be developed and refined, for example, water quality metrics have not yet been developed in a standardised way. Standardising the natural capital measuring approach across different countries may also be demanding as countries can use different indicators depending on their specific needs.

For provisioning services, such as timber, it is more straightforward to determine stocks and stock changes, whereas this is more problematic for regulating and cultural services. Typical accounting uses positive values for flows, so it can be difficult to account for ecosystem disservices (e.g. crop pests or diseases), which will have negative effects. In contrast to economic considerations, which have monetary value as a common metric, ecosystem services are measured in different ways so comparison or totaling across different ecosystems and service is difficult.

Quality and availability of data are also critical. The availability of data varies for different ecosystems, for example, marine ecosystems may have limited information on biodiversity distribution. Applying accounting systems consistently across all ecosystems is therefore a challenge. In addition, many aspects of ecosystems are not monitored adequately to enable accurate ecosystem accounting. Carbon measurement, for example, is difficult and subject to uncertainties, such as those in carbon stocks for different vegetation and soil types, which are location specific.

Measuring ecosystem stocks and flows can also be resource intensive, especially over large areas. In some cases, data may be available but not at the appropriate scale for the accounting assessment. As posited in Remme, Schröter and Hein (2014), inaccurate or incomplete data will increase errors in modelled results.

General measurement issues include using information across different spatial scales i.e. country or regional level as well as scaling data up, as information is often only available for specific sites, which needs to be used on a larger scale. Length of accounting period is also an important consideration for ecosystems as different processes can be observed more easily over different time periods.



Vine Weevil, Otiorynchus sulcatus. Derek Parker, 2014, Flickr. [CC BY-NC-ND 2.0](https://creativecommons.org/licenses/by-nc-nd/2.0/)

Going forwards, Remme, Schröter and Hein (2014) suggest that BSUs could be enhanced by incorporating a wider range of data types, such as socioeconomic information (e.g. economic activities, land management techniques).

Another constructive critique of the SEEA-CF/EEA system is that it only values ecosystem assets via considering net present value of presently expect ecosystem flows — so doesn't consider the capacity of ecosystems to provide services. The SEEA-EEA also doesn't consider how ecosystem service flows will be affected by use of multiple services, the prioritisation of a single service over a basket of services, or the ability of the ecosystem to generate services regardless of demand (or otherwise). To respond to these critiques, Hein *et al.* (2016) propose that the SEEA-EEA method be refined further by extending the set of terms needed to understand ecosystems as assets. These further categories include capacity (sustainable use levels of multiple ecosystem services), capability (prioritisation of a single service over a basket of services) and potential supply (ecosystems' ability to generate services irrespective of demand for such services).

3. Economics and NCA: valuing ecosystem assets and services in national accounts

An important aim of the ecosystem services concept is to make explicit the benefits that ecosystems provide (Science for Environment Policy, 2015), and one way in which this can be achieved is using valuation. The most common method of valuation is economic, as this can allow a relatively simple form of comparison across various services once they are described in the common form of monetary currency.

There are many who think economic valuation can be an important means of protecting ecosystem services (Atkinson, Bateman & Mourato, 2012; Schröter *et al.*, 2014), one of a host of tools, by assigning ecosystems a value they may not otherwise be assigned. Economic valuation can also be very useful for comparing the effects of different policies (Schägner *et al.*, 2013; Schröter *et al.*, 2014).

On the other hand, the UN's guidelines (United Nations, 2014) acknowledge that "attempts to place values in monetary terms on ecosystems may be considered inappropriate and potentially misleading." Similarly, a report from an EU Mapping and Assessment of Ecosystems and their Services (MAES) stressed that valuation and accounting are not synonyms and valuation is not simply «the end product» of accounting (MAES delivery workshop, 2015). Others say that one needs a pluralistic approach to determining values and decisions related to them, and that purely monetary approaches have significant limitations. Such pluralistic approaches can include monetary values but also include a range of values that are not easily (or cannot) be described in monetary terms^{2,3,4}.

3.1 Methods of economic valuation

Natural capital can be valued in a benefit- or value-based way, or in a cost-based way. There are a variety of motivations for carrying out economic valuation, including modelling different policy

scenarios, conducting cost-benefit analysis, comparing valuations within the system of national accounts or raising awareness of the importance of the natural environment. It is important that the motivation and purpose of analysis is aligned with the choice of valuation concept and method.

A simple, benefit-based form of economic valuation is to apply market prices directly to 'use values' — i.e. the value conferred upon a product by its usefulness (Atkinson, Bateman & Mourato, 2012). There are a variety of more complex methods, including 'production function', whereby ecosystem services are valued as 'productive inputs', such as flood protection. These are not directly associated with a market value but underlie important functions (Barbier, 2007).

Cost-based techniques, which use market prices to estimate the monetary value of ecosystem services. One example is the 'avoided costs' approach, such as the economic damage from flooding that could be avoided by the sustainable management of floodplains; 'replacement cost', such as the mechanical purification of water necessary to replace the natural function provided by healthy ecosystems; and 'restoration costs', which reflect the costs of restoring a damaged ecosystem (ten Brink *et al.*, 2015). These proxy methods assess the costs that are avoided due to ecosystem services or the costs that may be incurred to replace/restore them, rather than the actual economic value. They are widely applicable to ecosystem restoration but present a risk of 'double counting' if they are combined with the values of the services supported by the systems (ten Brink *et al.*, 2015).

Monetary valuation of ecosystems is often achieved using Total Economic Value or TEV — whereby different types of monetary value are added up, providing a comprehensive picture of the economic value of the environment (Gómez-Baggethun *et al.*, 2014). The TEV concept divides the economic value of ecosystem services into use values — such

2 <http://www.sciencedirect.com/science/article/pii/S1877343517300040>

3 http://www.openness-project.eu/sites/default/files/Deliverable%204%201_Integrated-Valuation-Of-Ecosystem-Services.pdf

4 <http://www.springer.com/gp/book/9783319172132>

as agriculture or fishing — and non-use values — reflecting the satisfaction people gain from the knowledge that ecosystem services are maintained for instance (Gómez-Baggethun *et al.*, 2014). More recent proposals (Pascual *et al.*, 2015) suggest additional layers, including reducing the risk of disturbance (self-protection) and reducing the magnitude of loss caused by a destructive event (self-insurance).

Many ecosystem services are not traded in markets and have no observable exchange values. In these cases, non-market valuation techniques such as revealed preferences and stated preferences can be used to estimate exchange values. Revealed preference methods determine the value of an ecosystem service based on observations of related market goods. They include the ‘Travel Cost’ method, which estimates the value of an area based on the amount of time and money people spend visiting it. Stated preferences are based on survey work, for example investigating people’s willingness to pay (WTP) for improved environmental conditions or the compensation they would require for a reduction in environmental quality.

Unlike other valuation methods, these can be used to quantify the non-use-values of an ecosystem in monetary terms. Studies using these methods can also be used to value ecosystem conditions that do not currently exist or ecosystem services that may become available in the future. Typically, no transaction takes place, so the WTP creates a consumer surplus (as the WTP is above the market price). These values therefore cannot be used directly to estimate exchange values compatible with the SNA.

These methods also rely on the reliability of individual responses, which can be problematic. Research suggests that people can be biased towards environmental loss over gain (Parks & Gowdy, 2013) and respond differently given the context of the interview (Bateman & Mawby, 2003). Further, an individual’s valuation may not be representative of the value held by society at large (Fish *et al.*, 2011). However, these simulated exchange values do have advantages in terms of simplicity and fit with the SNA.

Clearly, economic valuations of ecosystem services can be complex; however guidelines such as the SEEA aim

to enable compilers and analysts of ecosystem accounts to make decisions on how to value assets and services while being aware of the required assumptions and implications for interpretation — for the individual resources that they feature. Values that lie outside a monetary framework can be more difficult to deal with, and there are many different approaches for their valuation, including a range of qualitative or quantitative representations of values.

3.2 Integrated valuation frameworks

While monetary valuation provides a useful means of quantifying ecosystem services, via a single common unit, some suggest that it is not possible to reduce nature’s value in this way (De Groot, Wilson & Boumans, 2002; Norton & Noonan, 2007; Parks & Gowdy, 2013); there is also great social, cultural and ecological value associated with ecosystems (Gómez-Baggethun *et al.*, 2014).

One approach to consider these diverse values is called ‘value pluralism’ (Gómez-Baggethun *et al.*, 2014), which requires an integrated valuation system. The EU-funded [OpenNESS project](#) is working to translate the concepts of natural capital and ecosystem services into useful frameworks for management and decision making. The project recently published a report (Gómez-Baggethun *et al.*, 2014) proposing a definition of integrated ecosystem services valuation as:

“The process of synthesizing relevant sources of knowledge and information to elicit the various ways in which people conceptualize and appraise ecosystems services values, resulting in different valuation frames that are the basis for informed deliberation, agreement and decision”.

The detail of their integrated framework was published in 2015 (Braat *et al.*, 2015), and describes a method for combining the values of ecosystem services, monetary and non-monetary, in a structure which links to policy objectives.

They have also created a web portal, [Oppla](#), an open platform and community, where natural capital, ecosystem services and nature-based solutions across

Europe can be discussed. Oppla provides access to a range of resources, including tools and techniques and a crowd-sourced enquiry service.

Another approach is proposed by Turner and Schaafsma (2015), the ‘balance sheet approach’ which captures in sequential fashion a number of monetary and non-monetary values in a decision-making framework.

3.3 Challenges and outlook for economic valuation of ecosystems in national accounts

According to ten Brink *et al.* (2015) there is no reason — except for tradition — that national accounting procedures cannot be adapted to incorporate the value of natural capital — or the value of the ecosystem goods and services it generates. Where markets, and market values, exist, valuation is not a major issue for natural capital accounting. Exchange values can be used for such marketed goods and services, which, in most cases will be included in national income accounting already. However, for non-market ecosystem services, the process of valuation becomes more complex and potentially problematic (ten Brink *et al.*, 2015).

In cases where additional goods and services are not captured in the standard national accounts, for example, related to air filtration services, these additional goods and services could be treated as additional consumption. This means that the supporting or regulating services could be captured as additional to the production of already measured goods and services, representing an increased in overall value produced (Obst *et al.*, 2016).



[One tonne of CO₂ at COP15. greens_climate. SecretName 101 CC BY 2.0](#)

How to aggregate different ecosystem services when they are recorded using different measurement units such as tonnes of CO₂ or timber or numbers of walkers is an ongoing issue. For example, when calculating a ‘price’, or exchange value, for each service: should clean air be given a higher value than access to clean drinking water or vice versa? It is tricky — and often misleading — to determine such values, since a price is a mechanism used to exchange goods and services, and we would not want to exchange clean air for clean water. For some non-marketed ecosystem services, cost-based techniques can be used as proxies for exchange values, if it is assumed that buyers would be willing to pay

the estimated cost. Other methods, such as simulated exchange, might be used to estimate exchange values.

All methods for attributing values for ecosystem services involve some estimation and, although the simulated exchange value provides a clear single price, it is often inconsistent with the actual quantity and has not been thoroughly tested. Some posit that there is therefore an ongoing need to develop approaches for assigning exchange values that are consistent with SNA principles and how value is derived from natural assets (ten Brink *et al.*, 2015).

Since the measurement unit for each flow of ecosystem services is different, other metrics for a ‘universal exchange value’ have been proposed. The SEEA-EEA guidelines suggest that weights could be established that reflect the relative importance of each service. Such weights could be derived from a different form of common currency, such as units of carbon or energy. The SEEA-EEA guidelines stop short of recommending such a universal proxy: they provide examples of measurement approaches that can be taken for some selected ecosystem services. They warn that such metrics may give the impression that ecosystem services are easily separable flows - which would not reflect how they operate in reality.

Overall, there is clearly room for improvement within methods of economic valuation. It is important to tackle gaps in understanding — both of how ecosystems function and how humans benefit from them economically — in order to develop more reliable valuations.

Perhaps two of the biggest criticisms of economic valuation are that, firstly, ecosystem value extends beyond the monetary — to cultural services and option values, such as protecting biodiversity to provide resilience against climate change (Science for Environment Policy, 2015); and secondly, that the moral or ethical duty to protect the environment should be paramount — and that the economic argument distracts or detracts from this. The fear is that these more tricky, ‘unaccountable’ issues may be neglected in the decision-making process, at a potential cost to the environment.

Pittini *et al.* (2013) identify some important principles for including non-marketed goods and services in national accounts:

- accept that accounting frameworks will never capture all values for nature. The aim is rather to “expand the production and asset boundaries of the national accounts, starting with values that are as close as possible to the market and proceeding to include non-market values that probably still reflect direct and indirect use values;”
- accept that some loss of precision in value estimates may be acceptable, for the sake of greater inclusivity;
- accept that monetary valuation, whether through exchange or welfare values, cannot fully address sustainability concerns: there are inevitable challenges such as nonlinearity, irreversibility and the limitations of marginal valuation that “point to the need for complementing monetary valuation and wealth accounting approaches with assessments of critical stocks, as well as to the importance of developing physical accounts and indicators”; and
- recognise, therefore, that monetary accounting depends upon and must be developed in parallel with physical accounting.

Patrick ten Brink *et al.* (2015) go further to say that, with a few exceptions, and because of their lack of robustness, monetary accounting should be avoided over the period to 2020 (the Aichi Target 2 deadline).

National accounts, as discussed in Section 1.1, were designed to focus upon particular stories about human progress; they are human constructs that were never designed to incorporate measures of human wellbeing — much less environmental wellbeing (Tinch *et al.*, in ten Brink *et al.*, 2015)⁵.

The necessity of transference activities from projects like OpenNESS highlights two distinct interpretations of natural capital accounting activities. One perspective is to see NCA as a technical activity, primarily linked to economic questions and needing, as a first priority,

⁵ See footnote 13 in ten Brink *et al.*, 2015, pp. 35, for a very brief history of national accounts — primarily developed as a means to assess potential military spending, and hence potential success at war — and their strategic and storytelling nature.

to fit within the pre-established System of National Accounts. This is the perspective generally taken by the operators of the UN's SEEA framework. Although statistical choices often involve (implicit or otherwise) value judgements, from this perspective, subjective judgements on or uses of these accounts would lie outside the preparation of the accounts — as a subsequent job for policy analysts, for example.

The other perspective is to see NCA as part of a broader effort to measure the sustainability of development (perhaps more linked to the World Bank's work to develop comprehensive wealth accounting). This second perspective is linked to the concept of 'strong sustainability' (see **Figure 11**), which proposes that natural materials and services cannot be duplicated — and so people must learn to live without depleting assets faster than they can regenerate (Farley, 2012). If an asset is depleted, the balance sheet for the country should be adjusted to reflect the loss of the asset and the loss of the services it provides. This represents a different way of thinking about how NCA can or should be used, involving a far more wide-reaching analysis of the global valuation framework, and could move society toward a different paradigm of economic progress. Rather than shaping natural resource values to fit inside current national accounts, a far broader and deeper shift in the global system of valuation could be achieved via NCA approaches; many argue this is necessary if we are to account for the vast range of non-market values that underpin and enable the economic world to exist.

Still other perspectives support a path of moderate change: through incorporating NCA as much as possible with the SNA, but also by producing a range of supporting satellite accounts that, are closely linked to SNA, but are not bound to employ exactly the same concepts or restrict themselves to data expressed in monetary terms. Such satellite accounts would give a chance to test and explore new methodologies which, over time, may become developed and accepted into the main framework. The question is how to embed ecosystems and services within accounting, whilst avoiding treating nature in an overly restricted way, or designing valuation mechanisms that lead to perverse, unwanted effects for the environment.

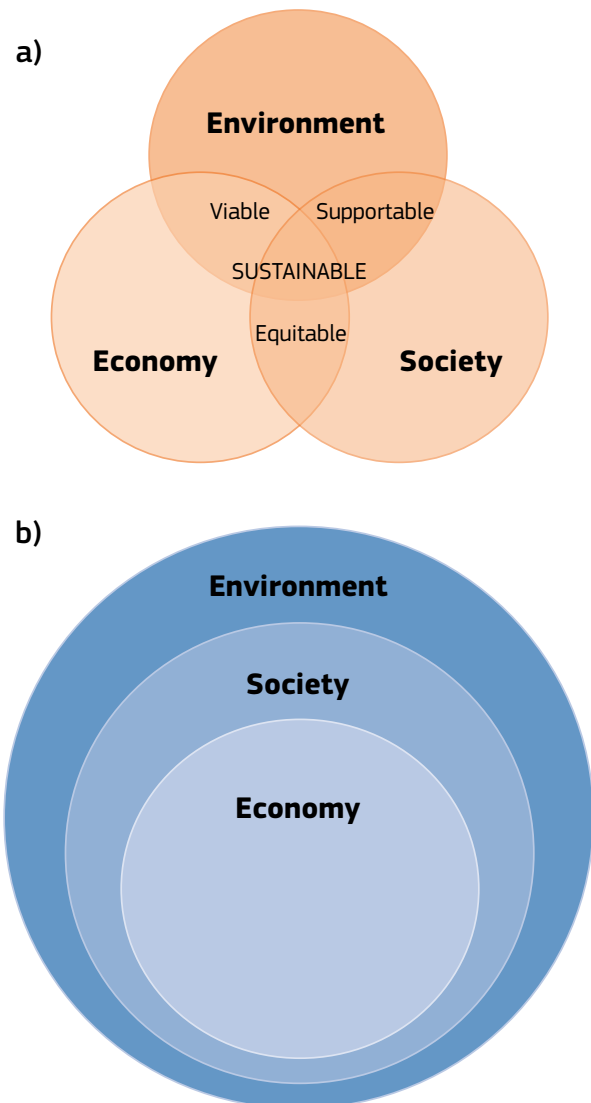

Figure 11: Schematics illustrating (a) weak sustainability and (b) strong sustainability. Adapted from Cheng and Hu, 2010.

It is worth considering that economic valuation is one of many tools in the toolbox, and that a balance needs to be achieved between feasibility of implementation and capturing all possible values. It is clear that current valuations should be analysed with care, and used to complement the other forms of valuation (including socio-cultural and ecological) as they evolve and are developed within a more comprehensive, accurate, diverse global values system⁶.

⁶ See for example UK National Ecosystem Assessment <http://uknea.unep-wcmc.org/>

4. Natural capital accounting in practice: refining and testing the protocols

Although the idea of accounting for natural resources has been around for several decades, the application of natural capital accounting is still in its infancy. However, detailed methods for building it into existing accounting systems have reached a state where they can now be tested.

If all countries adopt the same framework, they can also share best practice, as happened with the development of the SNA. Ideally, as countries and businesses test NCA methods in real-world situations, the new knowledge generated would be used to refine the guidelines, make them fit for purpose and adapt

them as new knowledge appears and as the world continues to change.

4.1 KIP INCA: refining and integrating NCA in the EU

Action 5 of the Biodiversity Strategy to 2020 states that:

“Member States, with the assistance of the Commission, will map and assess the state of ecosystems and their services in their national territory by 2014, assess the economic value of such services, and promote the integration of these values into accounting and reporting systems at EU and national level by 2020.” (Action 5, Target 2, EU Biodiversity Strategy to 2020).

To support this action, a number of EU-level activities were launched.

A Knowledge Innovation Project (KIP) on Integrated Systems for Natural Capital Accounting (INCA) in the EU was initiated in 2015 to strengthen the knowledge base that will feed into national capital accounts. Its objectives are to: integrate the existing, available data into a common geospatial platform in a way that will avoid bottlenecks in data processing, and to aid the stepwise

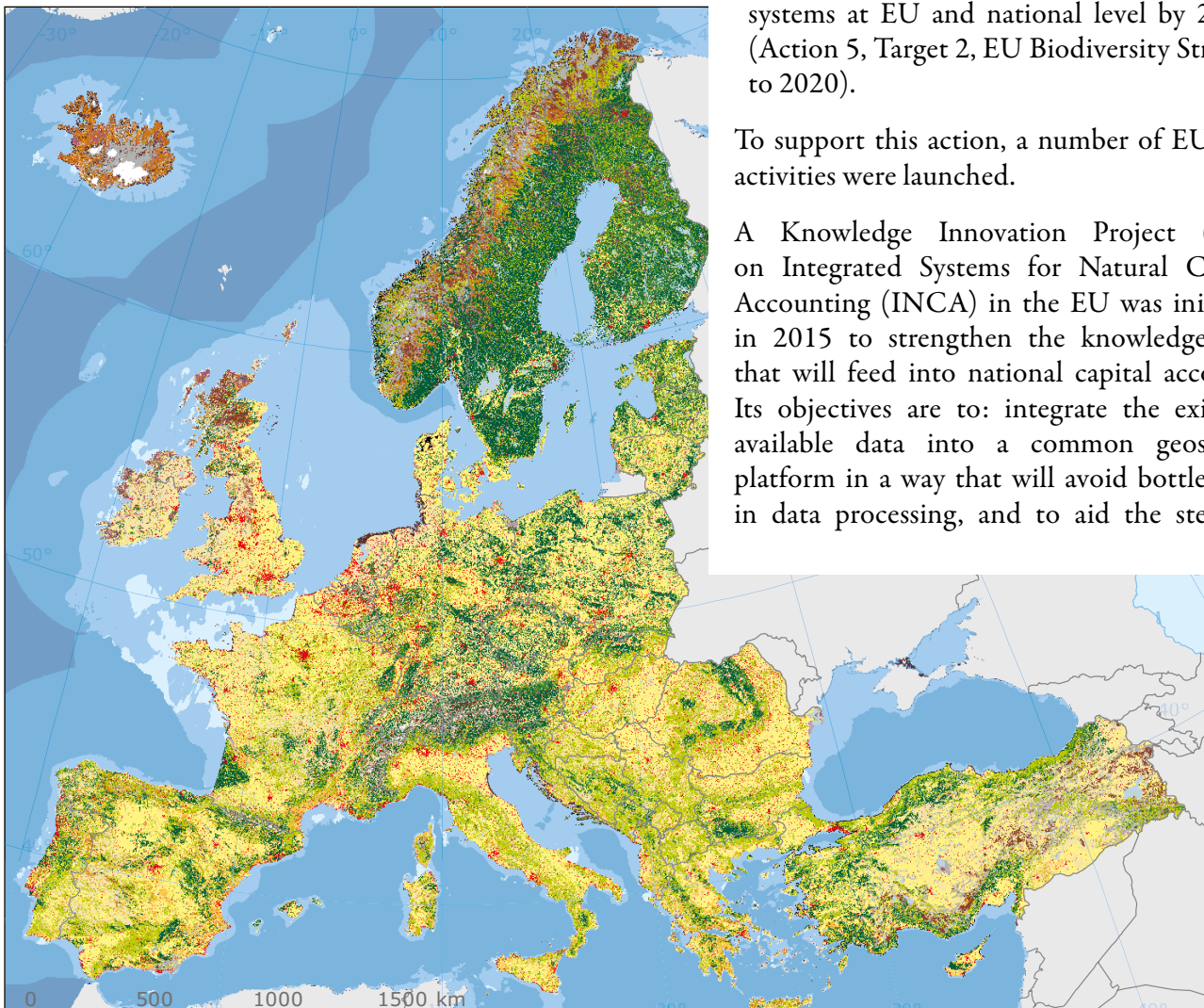

Figure 12: Ecosystem map for EEA-39(version 2.1) Note: EUNIS classes with little spatial extension were aggregated for clarity. Source: EEA, 2015, based on analysis by ETC/SIA.

Box 2: The Mapping and Assessment of Ecosystems and their Services (MAES) Working Group

MAES has been set up in order to produce a coherent analytical framework for EU-wide ecosystem assessment (see Figure xx for conceptual framework). Maps of ecosystems are useful for prioritisation and identifying synergies, trade-offs and problems among different ecosystem services, and also as a visual communication tool, to facilitate discussion. The outputs will help to understand better the baseline situation of European ecosystems and subsequent changes, what this situation means for society, and how changes may affect these values.

There is an interactive map — the MAES digital atlas — which aims to present: information on ecosystem services and ecosystem types collected so far; and a catalogue of case studies, which cover various scales and foci, not necessarily addressing specific ecosystem services, but which still contain relevant information for assessment. Only information published at a European, national or subnational level are collated there, and the tool will evolve as more information is added.

<http://biodiversity.europa.eu/maes/maes-digital-atlas>.

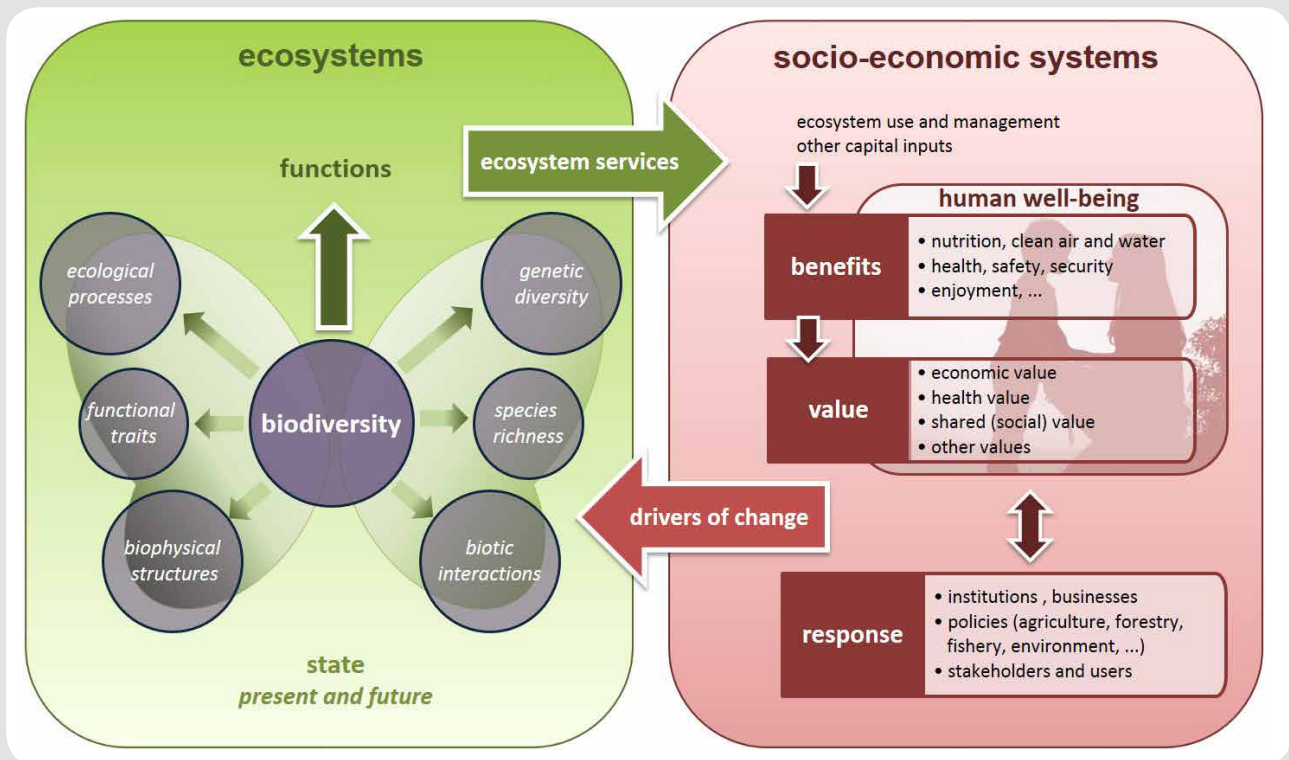

Figure 13: Conceptual framework for EU wide ecosystem assessments. Source: Maes *et al.*, 2013.

Ecosystem map (aggregated)		
Marine waters	Inland vegetation and habitats	Inland unvegetated or sparsely vegetated habitats
<ul style="list-style-type: none"> Open waters European regional seas 	<ul style="list-style-type: none"> Tundra Arctic, alpine and subalpine scrub and grassland Mediterranean-mountain scrub and bushes Heathland scrub Grasslands and land dominated by forbs Regularly or recently cultivated agricultural, horticultural and domestic habitats Sparsely wooded grasslands Broad leaved deciduous and evergreen woodland Mixed deciduous and coniferous woodland Coniferous and broad leaved evergreen woodland Mires, bogs and fens 	<ul style="list-style-type: none"> Scree, inland cliffs Snow or ice-dominated habitats Miscellaneous inland habitats with very sparse or no vegetation
Marine seabed and coastal habitats		Human made constructions and habitats
<ul style="list-style-type: none"> Sublittoral sediment Infralittoral and circalittoral rock and other hard substrata Marine habitats Coastal habitats 		<ul style="list-style-type: none"> Constructed, industrial and other artificial habitats
Inland surface waters		Non classified areas
<ul style="list-style-type: none"> Inland waters and shores 		<ul style="list-style-type: none"> Unclassified areas Outside area of interest

Key for Figure 12, facing page.

Box 3: List of possible EU data sources for integration under INCA

MAES framework:

- EEA datasets and monitoring systems: core ecosystem accounts for ecosystem extent, ecosystem condition and some thematic accounts (land, water and others), and development.
- Environmental reporting from MS under EU legislation.
- COPERNICUS: previously known as GMES (Global Monitoring for Environment and Security), the European Programme for the establishment of a European capacity for Earth Observation.
- LUCAS: Land Use/Cover Area frame Survey (LUCAS): a survey that provides harmonised and comparable statistics on land use and land cover across the whole of the EU's territory.
- Population and agriculture censuses.
- Farm Structure Survey: provide harmonised data on agricultural holdings in the EU.
- [ESTIMAP](#): a gis-based model to map ecosystem services in the European union.
- LUISA: Territorial Modelling Project <https://ec.europa.eu/jrc/en/luisa> based upon the notion of land function — a new concept for cross-sector integration and for representing complex system dynamics.
- GEO/GEOSS projects, accessible via the GEOSS portal (integrated with) accounting data of Eurostat.

approach towards a common methodology for EU natural capital accounts. This integrated data platform will enable efficient data sharing, and the production of derived data to underpin further analysis (EC, 2016d). As it progresses, the project will test the SEEA-EEA accounting methodologies and strengthen the knowledge base required to implement the 7th Environmental Action Programme. Wherever possible, it links up with the UN proposals for a global accounting system for natural capital.

Experimentation and research will play a crucial role in testing and refining Natural Capital Accounting protocols, and the results from the EU will help inform the development of international standards. National projects are also underway to create pilot accounts, and these experiences will also allow analysis to be conducted on what works well and what gaps or challenges need to be addressed.

In developing an integrated system (INCA), data will be brought together from a variety of existing data collections, structured in terms of the Mapping and Assessment of Ecosystems and their Services (MAES) framework (see Box 3), and related in a nested structure. The KIP-INCA project is clear: data sets will be integrated by EU-level bodies, at no extra work or cost for Member States, but Member States will be able to 'plug in' their national accounting systems to KIP-INCA. The Directorate-General for Environment, which is a main project partner — along with Eurostat, the European Environment Agency, DG JRC and DG RTD — states that biophysical and economic data to the extent and condition of ecosystems should be integrated in a systematic way, so that they can be aggregated and disaggregated at the required scale to complement figures of economic performance (EC, 2016). To date, work has started on developing basic extent accounts in the EU, and a selection of specific ecosystem services such as pollination and water-related services. Work has also aimed to integrate policy applications with the development of accounts. The design of an integrated geographically referenced knowledge platform has also started, that will be able to integrate data from a range of sources such as data reported under EU Directives, CORINE land cover, COPERNICUS (satellite observation land monitoring) data and LUCAS (ground observation) data, and others (EC, 2017).

Analytical step	Action and information requirement
Mapping ecosystems	Define a typology of ecosystems suitable for the European scale, and map their spatial extent based on their biotic and abiotic characteristics (data from the Corine land cover and EUNIS habitats databases, bathymetry, elevation, soil and other reference data)
Mapping pressures on ecosystems	Assess direct and indirect pressures (habitat change, climate change, overexploitation, invasive alien species and pollution) and their trends in space and time (data from many sources)
Assessing condition of ecosystems	Use data on habitats, species and environmental quality to define condition of ecosystems (EU directives reporting and other sources). Changes over time can show how pressures have affected habitat quality, biodiversity and the capacity to supply ecosystem services
Mapping condition of ecosystems	Condition can be mapped if data on condition are available in sufficient spatial detail (frequently poor data)
Links between ecosystem condition and ecosystem services	Collect information, quantitative if available, about how ecosystem condition affects habitat quality, biodiversity and the capacity to supply ecosystem services (data gaps)
Mapping ecosystem service capacity	Combine ecosystem maps with data on condition and on the links between condition, functions and ecosystem service capacity (data gaps)

Table 3: Data and information needs for Europe-wide ecosystem assessment. Source: Adapted from information in EC, 2016b. Note: Corine, Coordination of Information on the Environment; EUNIS, European Nature Information System.

4.2 Testing of Natural Capital Accounting protocols

Some countries have taken initial steps to account for their natural capital. This section provides samples of the work that has been achieved by several countries, particularly focusing on governmental, or government-supported work, within and outside of Europe.

4.2.1 Europe

The Netherlands

One of the most comprehensive implementations of the UN SEEA Experimental Ecosystem Accounting framework in Europe has been achieved in the Netherlands.

In a pilot project in Limburg Province (see Chapter 2.2), Statistics Netherlands and Wageningen University created a national map of ecosystem types, showing land use and vegetation properties at a high level of

detail (de Jong, 2016). For example, it shows water types, roads and other paved surfaces, built-up areas including residential and business use, agricultural land, meadows, natural grasslands, different types of forest, and even hedgerows of more than six metres wide.

The land divisions are consistent with the SEEA EEA ecosystem unit types and MAES. However, the project team comments that the SEEA EEA classification system “does not generally provide suitable classes for the Netherlands, and in its current form it does not contain enough detail for the analyses that were required”. For example, the SEEA’s ‘open wetlands’ ecosystem accounting unit covers a large number of wetland types, including bogs and mires, which may have a varying degree of cover by trees and shrubs. Coastal dune areas and river floodplains have therefore been classified by the Netherlands project in more detail than suggested by MAES or SEEA.

In addition, the project developed an Economic Users map to identify who benefits from the assets. Economic Users include agriculture, mining, retail, financial and insurance activities, public administration and arts. Natural capital accounting tables were also created. The SEEA guidelines do not prescribe the content or design of tables because each country will vary in the availability and quality of data. The tables were completed for Limburg, comprising 31 different ecosystem units. Data were inserted for the physical supply of eight ecosystem services: crop production, fodder production, drinking water extraction, hunting, carbon sequestration, the capture of particulate matter, recreational cycling and nature tourism.

Physical supply table (summarised) for selected ecosystem services in Limburg Province. Source: de Jong *et al.*, 2016.

The tables enabled some interesting analysis to take place. For example, nature tourism is provided by many of the ecosystem units and forests and hedgerows are shown to attract the greatest number of visitors. Hedgerows may not seem an obvious attraction, but in South Limburg many of them are located alongside sunken lanes or near nature reserves, contributing to a rich landscape that attracts recreational users.

	Ecosystem Services	Ecosystem Units	Non-perennial plants	Perennial plants	Meadows (for grazing)	Hedgerows	Farmyards and barns	Deciduous forest	Coniferous forest	Mixed forest
	extent (ha)		53.600	8.100	27.100	2.900	2.100	11.400	7.100	10.400
Provisioning	Crops	tonnes/yr	1.427.300	65.000	-	-	-	-	-	-
	Fodder	tonnes/yr	140.800	4.700	328.700	-	-	-	-	-
	Meat (from game)	kg/yr	11.500	1.500	5.900	800	400	2.500	1.700	2.900
	Ground water (drinking water only)	In 1000m ³ /yr	9.000	1.400	4.200	500	100	1.900	100	500
Regulating	capture of PM10	tonnes/yr	400	100	200	-	-	300	400	500
	Carbon sequestration	tonnes/yr	-	2.400	4.900	500	-	16.500	10.300	15.100
Cultural	Recreation (cycling)	1000s of bike trips/yr	1.800	300	1.000	100	100	600	200	400
	Nature tourism	# tourists/yr	94.000	22.000	136.800	57.000	-	160.300	93.800	147.400

Table 4: Physical supply table (summarised) for selected ecosystem services in Limburg Province. Source: de Jong *et al.*, 2016.

A further table was created to show the condition of the ecosystem units. The indicators of condition include the degree of environmental protection, climatic parameters, such as rainfall and temperature, species richness, water quality, the annual number of growing days and the heavy-metal content. Data for a single year was entered and will allow comparisons to be made in future.

A separate report has assessed the contribution of the 31 ecosystem units to Limburg's regional economy, following the UN SNA accounting rules (Remme *et al.*, 2015). Crop production, nature tourism and groundwater supply for drinking water production

were identified as having the highest per-hectare value. However, in this study, protection against river floods was not included as an ecosystem service. If it had been included, floodplains would have had a much higher per-hectare value.

The researchers also highlight limitations associated with using the valuation methods of the SNA. For example, consumer surplus is not included. In the case of air filtration, a welfare-based valuation approach would lead to a value around four times higher than the SNA assessment (Remme *et al.*, 2015).

Heath land	Inland dunes	Fresh water wetlands	Natural grassland	Public green space	Other unpaved terrain	River flood basin	Paved surfaces	Lakes and ponds	Rivers and streams	Totals
2.100	100	900	3.100	4.800	22.600	14.100	42.300	3.100	3.800	220.900
-	-	-	-	-	-	-	-	-	-	1.492.400
-	-	-	-	-	-	66.900	-	-	-	541.100
600	-	200	800	900	4.700	2.400	-	-	-	36.800
100	-	-	700	400	2.400	1.300	3.800	500	-	27.000
-	-	-	-	100	200	100	-	-	-	2.300
400	-	200	600	1.200	4.100	2.800	-	-	-	59.000
-	-	-	100	200	1.300	600	2.100	100	-	9.100
22.700	1.000	11.600	55.400	11.800	65.900	94.500	-	100	-	974.300



England's natural environment is said to provide the foundation of sustained economic growth, prospering communities and personal wellbeing in a 2011 government White Paper. Image source and info: <https://pixabay.com/en/england-countryside-yorkshire-1637901/> (no attribution needed)

The United Kingdom

The first analysis of the benefits of the UK's natural environment to society and economic prosperity was reported in June 2011 (UK National Ecosystem Assessment (NEA), 2011). A number of changes to natural capital policy and management have since been made.

The analysis assessed eight habitat types along with examples of the goods and services derived from each. It suggested that nearly a third (about 30%) of the ecosystem services were declining, including soil quality and pollination. Many others were in a reduced or degraded state, including marine fisheries and wild species diversity. Reductions were associated with declines in habitat extent or condition and changes in biodiversity.

It concluded that while some of the most important individual species and habitats were being successfully

maintained and enhanced, a larger scale effort was needed to support more species and whole natural systems.

At the same time, the Government's Department for Environment, Food and Rural Affairs published a natural environment white paper (DEFRA, 2011) in which it was recognised that a healthy natural environment is the foundation of sustained economic growth, prospering communities and personal wellbeing.

Key reforms have since been put in place. A new independent Natural Capital Committee was established to advise the government on the state of English natural capital and the government committed to capture the value of natural capital in a national balance sheet. In addition, a business-led Ecosystem Markets Task Force was established to review the opportunities for UK business from expanding green goods, services, products, investment vehicles and

markets which value and protect nature's services, and the government committed to provide new support and guidance for businesses to capture the value of nature through responsible supply chains.

Since its inception, the Natural Capital Committee has published an annual State of Natural Capital report. The first, published in April 2013, set out a framework for what needed to be done to ensure that the significant economic and wellbeing benefits that natural capital can provide are secured through better valuation and management. In the second, it recommended that the government endorse a proposal to develop a 25-year, landscape-scale plan. This would help the government deliver an ambition from the

2011 White Paper "to be the first generation to leave the natural environment of England in a better state than it inherited".

Another important milestone in the UK was a first attempt to estimate a monetary value of the country's natural capital, published every year since 2013. The UK Office for National Statistics accounted for the values of UK woodland ecosystems. Their study considered three ecosystem services (timber production, carbon sequestration and recreation), calculating monetary flows for them. **The first published results show that, in 2009 to 2013, the value of a tree was roughly 15 times that of its timber value (with values ranging from 24 times to 14 times), based on only these three ecosystem services (ONS, 2015).**

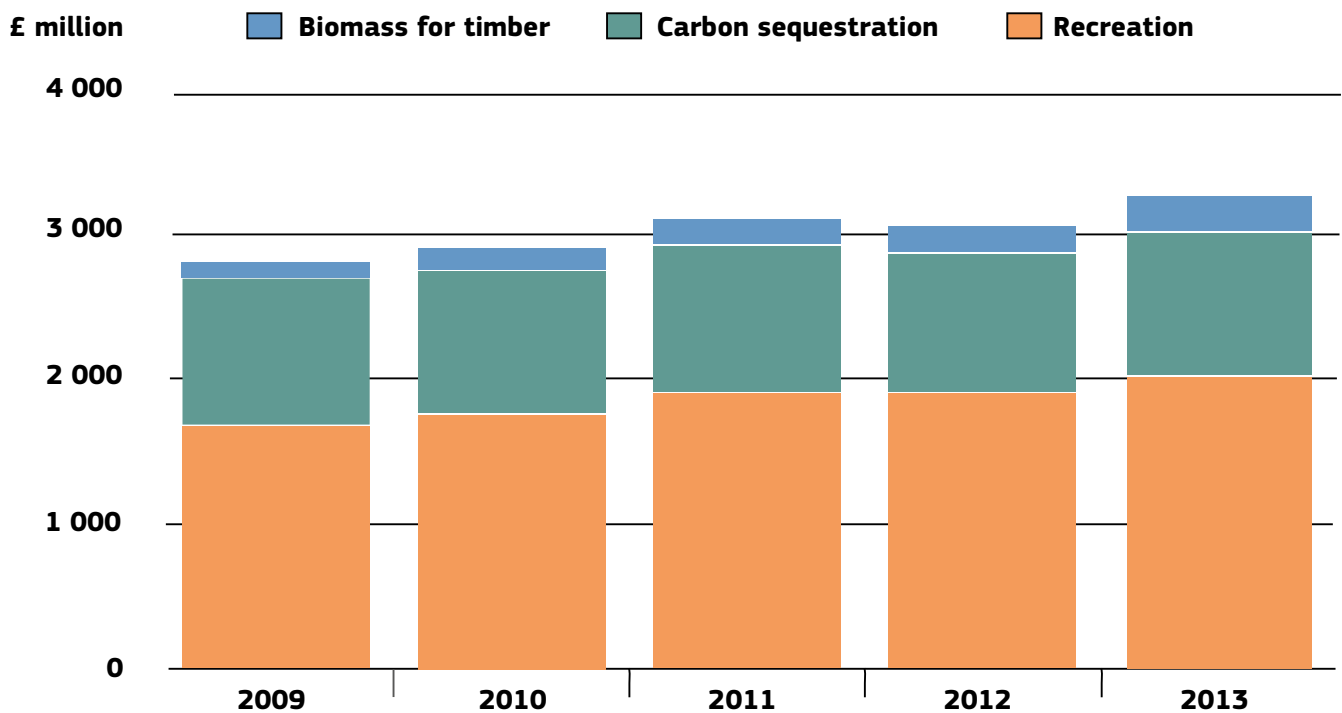

Figure 14: Value of 3 woodland ecosystem services, 2009 to 2013., United Kingdom. Source: ONS, 2015. Note: Prices are in 2013 constant prices. Office for National Statistics UK Environmental Accounts 2015 Statistical bulletin.

4.2.2 Outside Europe

There have been several efforts to advance the testing of NCA outside of Europe. Outlined below are some of the activities, findings and outcomes from two major projects engaged in NCA.

UNEP / UNSD / CBD project on Advancing Natural Capital Accounting funded by NORAD

This project aims to test the relevance and feasibility of the SEEA ecosystem-accounting approach in seven pilot countries: Bhutan, Chile, Indonesia, Mauritius, Mexico, South Africa and Vietnam. Some details for South Africa and Mexico are provided below.

KwaZulu Natal, South Africa

A number of environmental accounts have been developed in South Africa. In 2009, Statistics South

Africa (StatsSA) published accounts on the amount of water used by various industries, and in 2014, it published updated accounts on energy, minerals and fisheries. In 2015, further accounts on river ecosystems and ecosystem in KwaZulu-Natal were published (Nel and Driver, 2015).

The river ecosystems report showed that the ecological condition of rivers generally worsened between 1999 and 2011: for example water quality in 5% of total river length was judged to be in a serious or critical state in 2011, compared to 3% in 1999. Declining water quality was attributed to failing waste-water treatment infrastructure and increasing pollutant loads from agriculture and disused mines.

Linking the trends found in these accounts with national water accounts and socio-economic indicators (e.g. from census information) is one of the next steps



Drakensburg Mountains, KwaZulu, South Africa. By Arno Meintjes. <https://creativecommons.org/licenses/by-nc-sa/2.0/>

to help with land use and water management policy. Combining this information is crucial for informing the use of river ecosystem services in a country that is semi-arid, with unpredictable rainfall patterns and frequent drought.

The ecosystem accounts for KwaZulu-Natal, meanwhile, showed that the extent of biomes (habitat types), including grassland, savanna and forest, all declined between 2005 and 2011. Their decline was particularly highlighted by comparisons with 1840 maps of their extent. Linking changes in land cover to other data (e.g. population) can again help to inform planning decisions. It is noted that biomes themselves cannot be linked directly to the provision of ecosystem services, as they are too heterogeneous, but the impacts of changes within the biomes can be analysed. For example, overgrazing of grassland on a slope may cause more soil erosion than on a flat plain. In addition, land cover can be a proxy for ecological condition, in the absence of other data. In this way, socio-economic drivers of change and ecological impacts could be investigated.

In order to implement the SEEA, StatsSA strengthened coordination between government ministries. This has led to new inter-departmental working groups which reduced fragmentation of basic environmental statistics, such as those relating to water, minerals, energy, climate change and biodiversity.

Aguascalientes and Colima, Mexico

As part of the implementation process in Mexico, the *National Plan for Advancing Environmental-Economic Accounting 2015* (NP-AEEA) was developed. It evaluates the viability of producing accounts for



Colima Volcano Mexican Flag. Jrobertiko, 2009, Wikimedia Commons. CC BY <https://creativecommons.org/licenses/by-nc-sa/2.0/>

Mexico and establishes guidelines for deliverables and delivery dates.

The priorities identified were: pilot water accounts, pilot land-cover accounts, pilot biodiversity accounts, case studies, the viability of producing carbon accounts, ecosystem condition accounts and supply and use of ecosystem services accounts. Pilot studies are centred on the Aguascalientes and Colima states. The idea is that the pilot studies will help evaluate the possibility of applying the methodology to the whole country.

Preliminary national water accounts were first made available in 2010. These indicated that at several watersheds, the volumes of surface water allocated through permits were higher than the total renewable flow. This can lead to unreliable access for competing uses, such as urban and agricultural uses. The water accounts have made an important contribution in building a bridge between national accountants and water experts to create a policy-relevant information system for water, according to a UNSD report.

The Victorian Central Highlands, Australia

The forested Central Highlands region of Australia provides nearly all Melbourne's drinking water and supports the tourism and forestry industry, as well as providing water for crop irrigation. A new 20-year



[A Leadbeater's possum called George: a victim of logging.](#) Tirin, 2013, Wikimedia Commons. CC BY-SA 3.0

forest management plan is due to be agreed by the national and state governments in 2018. A suite of environmental accounts, based on the SEEA protocols, has been compiled to inform decisionmakers working

on this agreement, by the Australian National University Fenner School of Environment and Society.

Dealing with land, water, carbon, timber, agriculture, tourism, biodiversity and ecosystem services, the accounts were published in 2016 and 2017. The value of water supply, at AUD\$310 million (€202 million) and tourism AUD\$260 million (€170 million) far outstripped the value of forestry in the area, helping policymakers to decide whether the latter should be permitted to continue, or whether conservation should come first. It is argued that putting an end to harvesting native timber in the area, worth AUD\$12 million (€8 million), would help to save the critically endangered Leadbeater's Possum and boost the value of other ecosystems.

The accounts make the trade-off explicit, and even raise the question of whether a carbon market would be appropriate, with the trees valued for their carbon storage.



Logging in Australia's Central Highlands. Peter Campbell, Wikimedia Commons. CC BY-SA 3.0, <https://commons.wikimedia.org/w/index.php?curid=30617169>



Mangrove jungle, Palawan, The Philippines. CC0. <https://pixabay.com/en/palawan-water-river-mangrove-jungle-172428/> (CC0)

4.2.3 World Bank WAVES project test sites

The WAVES programme has been set up to help countries adopt and implement natural capital accounts that are relevant for policy and decisionmaking, and help them to compile a body of evidence to develop approaches to ecosystem accounting methodology — in aid of building international consensus around NCA. Botswana, Colombia, Costa Rica, Madagascar, and the Philippines were the initial core implementing countries, and Guatemala, Indonesia and Rwanda joined as core implementing countries in 2013. Progress reports are available on the eight participating

countries of the WAVES Partnership. Some details for the Philippines and Colombia are provided below.

Southern Palawan, Philippines

Ecosystem accounts have been created for the Laguna Lake basin and the southern Palawan region of the Philippines. About a fifth of the population of the Philippines rely on Lake Laguna for water, food, energy and recreation and for their livelihood and southern Palawan harbours species-rich protected areas, including a significant share of the country's remaining forests. Intensive pressure on the natural environment here comes from competition for resources from a number of sectors: agriculture, logging, fishing,

natural gas exploration and ecotourism. This pressure threatens some of these sectors, for example, a dramatic decline in coral reef quality could affect ecotourism and mangrove systems are in decline leaving the country more at risk from natural disasters.

Accounts generated include a land account (including land cover and changes), an ecosystem condition account including water quality indicators, and an ecosystem production account looking at services including fishery production, flood retention and soil erosion regulation.

These showed that about half of the value of production from rice and coconut can be lost due to ecosystem degradation (WAVES, 2015) and that forests are needed for maintaining water supply. However, the total carbon stock of forests declined between 2003 and 2010 and southern Palawan became a carbon emitter. Since then, a nationwide illegal logging ban has been enforced and a National Greening Program implemented. A modest recovering of closed forest meant that by 2014 the region was again a carbon sink.

Lake Tota, Colombia

There is a long history of environmental accounting in Colombia, which as a region ranks second in the world for total biodiversity, and first for number of bird species and water resources. In 2006, however, the World Bank estimated that environmental degradation was costing the country the equivalent of 3.5% of GDP. This was chiefly attributed to deforestation due to agricultural conversion. WAVES in Colombia therefore aims to incorporate natural capital accounts in policy, in critical areas identified by the WAVES Technical Committee.

The first area to receive attention under the WAVES initiative has been Colombia's watersheds. Pilot accounts for Lake Tota showed that it is the source of drinking water for around 160,000 people, and supports the production of about two-thirds of the spring onions grown in the country. Information of emissions causing pollution in the lake have also been compiled (e.g. untreated sewage and fertiliser run-off), indicating threats to its aquatic ecosystems. Finally, an account showing the relative economic

productivity per unit of water from the lake has been created, showing that hotels are the most profitable users of the lake's water, followed by livestock farming. The accounts offer insights for analysing the contribution of the watershed to the local economy and are used by the regional authority to inform water management plans. Further accounts are being compiled for the Chinchiná and Alto Suárez rivers. (WAVES, 2016c)



Lake Tota. Petrus, Wikimedia Commons. CC0, <https://commons.wikimedia.org/w/index.php?curid=12563940>

5. Conclusion

Human life hangs in the delicate balance of natural capital use and protection. Despite its underpinning, pivotal role in providing for society and economy, far less data is systematically gathered on the environment than for economic and social measures of productivity, prosperity, health and wellbeing. There is a pressing need to make sure that the assets and services delivered by natural capital are considered in the economic and planning decisions that put them at risk.

of biophysical accounts: they will need to overcome resource limitations to be scaled up and standardised; to increase in availability and quality; and to integrate with measures of productivity, growth or national accounting. Other measures have also been proposed, which capture concepts that will contribute to a more accurate and detailed assessment of the benefits ecosystems provide (or could potentially provide). These include capacity, capability and potential supply.



Brisighella - Emilia Romagna, Italy. © Flavio Vallenari, iStock.

Some current work in the field of natural capital accounting is focused on developing and testing methods to measure biophysical values. Measuring natural capital in biophysical terms entails not just documenting the size and types of different ecosystems, but also their condition, across different spatial and statistical units. Biophysical data are still a few steps removed from full economic integration, although they can be used to track changes in ecosystems and link those changes to economic and other human activity — providing an effective way to quantify the benefits of ecosystems to society. The biophysical values of ecosystems can be measured in ‘stocks’ and ‘flows’, which partly aligns them with national accounting terminology — but there is still a lot of work to do before these two different systems can be made coherent. Beyond the terminological differences, there are other challenges in the application

Indeed, several researchers confirm that ecosystem functionality — the synergies, trade-offs and thresholds that enable an ecosystem to produce services — are a crucial area in which to increase our understanding, the better to take them into account.

Valuation of ecosystem services (in a number of forms, both monetary and non-monetary) is of importance to policymakers, businesses and environmental organisations in that, by quantifying and making explicit the value of the environment in currently existing language: it helps to raise awareness of the benefits; it can target resources for ecosystem protection; and can rationalise the decision-making process (Science for Environment Policy, 2015). There are several projects that have been refining and testing natural capital accounting. In the EU, the KIP-INCA project is working to strengthen the knowledge base that will

feed into ecosystem accounts, and is in the process of resolving questions about the level of integration desirable and achievable. The UK and the Netherlands have done some of the most thorough work on a country level. South Africa and Mexico, Philippines, Colombia and Australia have achieved particular progress in the application of ecosystem accounts, and continue to extend the current limits of testing. There are a handful of notable advances from businesses in conducted pilot studies, or stating policies, principles and aims to integrate NCA into their practice.

Some thematic areas can be identified as having potential for greater NCA opportunities, at least in the short term and where they have could have policy relevance: agriculture and food production, water supply and regulation and carbon sequestration and storage, or specific services such as pollination. It might be that these should be given greatest prominence for research and application, because of the high risks associated with loss of ecosystem functions in these areas, but also because they can be linked to business interests without too much manipulation. Trials in such areas could be used to refine and embed the methodologies, leading the way for other functions and compartments.

Biodiversity, however, is less well defined and advanced in measurement methods and accounting, as are the fundamental links to ecosystem condition. There are many indications that biodiversity provides an essential base for other services to function, but it is difficult to assess this relationship quantitatively. The contradiction between its importance for ecosystem function, and the challenges of measurement, make it an important area for consideration by NCA researchers.

Similarly to other research streams on ecosystem services, there are services that are less commensurable than others: namely, the cultural, spiritual, ethical or aesthetic values, which still do not seem to fit within an ecosystem-services accounting approach — or, at least, we seem a long way off. Some researchers advocate that we should not seek such global inclusion, and instead aim to provide appropriate space for ill-fitting values, so these important cultural and moral values will not be dismissed as hidden externalities (Chan *et al.*, 2012).

Natural capital accounting is viewed by most working in the field as an ongoing process and multilogue, the details and evolution of which will be better understood through detailed application of the methodologies.

Indeed, ten Brink *et al.* (2015) posit that it is not as important to have accounts that are strictly accurate, as important that they are consistent across space and time. For example, observing a change in values over a period of years will indicate something significant is happening, about which decision-makers could take note.

As data gaps are addressed and methods are refined, several researchers in the field assert that the next steps are to work to integrate natural capital accounts into standard accounting and therefore into high-level decision-making. Over time, with consistent measures, across different scales and across different countries, a useful picture will be built, and useful comparisons will be made; the hope is that such accounts will one day be considered on a par with other national statistics and accounts. However, to ensure such integration into decision making it is necessary to actively test and demonstrate policy applications as work evolves — otherwise NCA could remain simply another interesting but ultimately hypothetical approach.

At the same time, pressures on ecosystems, species and flows of services are continuing to grow. Natural capital accounting is one tool to understand better the planet and its environment, and to assign more accurate values to the environment's overarching role in supporting human life and endeavours. If it seems the process of implementing NCA is painfully slow, perhaps it is because it is necessarily a highly meticulous and detailed discipline — and there are many research and implementation challenges still to overcome. When measured against some current rates of ecosystem change or degradation, we need to see it as an evolving tool alongside a range of other tools and forms of information that contribute to a 'toolbox' for decision making.

The potential of NCA is significant; for example, the historically determined country 'rankings' of the global economy might be transformed if accounts of natural capital gain recognition alongside GDP as future measures of national wealth. When it comes to the ecosystems we depend on, there is a need to continue testing accounting approaches and demonstrating policy applications in a variety of contexts. It is clear the need for a workable system of natural capital accounting is only going to increase: supranational organisations, states, governments, regions and businesses alike will need to build their commitment to strengthen the evidence base.

References

- Atkinson, G., Bateman, I. & Mourato, S. (2012) Recent advances in the valuation of ecosystem services and biodiversity. *Oxford Review of Economic Policy*. 28 (1), pp. 22–47.
- Austrheim, G. *et al.* (2016) Synergies and trade-offs between ecosystem services in an alpine ecosystem grazed by sheep — An experimental approach. *Basic and Applied Ecology* 17(7): 596-608. <http://dx.doi.org/10.1016/j.baae.2016.06.003>
- Australian Bureau of Statistics (2015). Information Paper: An Experimental Ecosystem Account for the Great Barrier Reef Region. Available from: <http://www.abs.gov.au/ausstats/abs@.nsf/mf/4680.0.55.001>
- AzkoNobel (2014). Measuring our impact in 4D. Azkonobel website. Available from: <http://report.akzonobel.com/2014/ar/case-studies/sustainable-business/measuring-our-impact-in-4d.html>
- Barbier, E. (2007) Valuing Ecosystems as productive inputs. *Economic Policy*. 22 (January 2007), pp. 177–229.
- Bateman, I.J. & Mawby, J. (2004) First impressions count - Almost double! A study of the interaction of interviewer appearance and information effects in stated preference studies. *Ecological Economics*. 49: 47–55.
- Bateman, I.J., Harwood, A.R., Mace, G.M., Watson, R.T., Abson, D.J., Andrews, B., Binner, A., (2013) Bringing ecosystem services into economic decision-making: land use in the United Kingdom. *Science* 341, no. 6141: 45-50.
- Braat, L. C. , E. Gómez-Baggethun, B. Martín-López, D. N. Barton, M. García-Llorente, E. Kelemen & H. Saarikoski (2015) Framework for integration of valuation methods to assess ecosystem service policies. European Commission FP7.
- ten Brink, P., Russi, D., Tinch, R., Schoumacher, C., Agarwala, M. & Bateman, I. (2015) The use of (economic & social) values of Natural Capital and Ecosystem Services in national accounting. OPERAs. European Commission.
- B@B (n.d.) Business & Biodiversity Campaign, Heidelberg Cement case study. Available from: <http://ec.europa.eu/environment/biodiversity/business/assets/pdf/innovation-case-studies/innovation-case-study-3-heidelberg-cement.pdf>
- Chan, K. *et al.* (2012) Rethinking ecosystem services to better address and navigate cultural values. *Ecological Economics* 74 (2012) 8–18
- Cheng, H. and Hu, Y. (2010) Planning for sustainability in China's urban development: Status and challenges for Dongtan eco-city project (Perspective). *J. Environ. Monit.*, 2010, 12: 119-126.
- Coen, R. (2016). Putting a Price on the Real Value of Nature. *Yale Environment* 360. Available from: http://e360.yale.edu/feature/putting_a_price_on_the_real_value_of_nature/2481/
- Constanza, R., d'Arge, R., de Groot, R., Farberk, S., Grasso, M., Hannon, B., Limburg, K., Naeem, S., O'Neill, R.V., Paruelo, J., Raskin, R.G., Sutton, P., van den Belt, M. (1997). The value of the world's ecosystem services and natural capital. *Nature*. 387, 253-260
- COM(94) 670 final. Directions for the EU on environmental indicators and green national accounting. The integration of environmental and economic information systems. COM (94) 670 final, 21 December 1994
- Defra (2014). Principles of ecosystems accounting. Paper by the Department for Environment, Food and Rural Affairs (Defra) and the Office for National Statistics (ONS).

- Defra (2013). A simple guide to Biodiversity 2020 and progress update. Available from: https://www.gov.uk/government/uploads/system/uploads/attachment_data/file/225300/pb14009-biodiversity2020-progress-guide-20130730.pdf
- Defra White Paper (2011). The Natural Choice: securing the value of nature. Defra, UK Government. Available from: https://www.gov.uk/government/uploads/system/uploads/attachment_data/file/228842/8082.pdf
- Diaz, R.F., Medrano, F.G. (no date) Experimental Ecosystem Accounting in Mexico Progress Report and Work Plan. Available from: http://unstats.un.org/unsd/envaccounting/londongroup/meeting21/EEA_Summary_Mexico.pdf
- Dickie, I., Cryle, P. & Maskell, L. (2014) UK National Ecosystem Assessment Follow-on. Work Package Report 1: Developing the evidence base for a Natural Capital Asset Check: What characteristics should we understand in order to improve environmental appraisal and natural income accounts? UNEP-WCMC, LWEC, UK.
- Dickson, B., Blaney, R. Miles, L., Regan, E., van Soesbergen, A., Väänänen, E., Blyth, S., Harfoot, M. Martin, C.S., McOwen, C., Newbold, T., van Bochove, J. (2014). Towards a global map of natural capital: Key ecosystem assets. UNEP: Nairobi, Kenya.
- EC (2016) Environmental Reporting Fitness Check. Monitoring and reporting of environmental legislation. European Commission. Available from: http://ec.europa.eu/environment/legal/reporting/fc_overview_en.htm
- EC (2016b) Mapping and Assessment of Ecosystems and their services: mapping and assessing the condition of Europe's ecosystems: Progress and challenges. 3rd Report - Final, March 2016. European Commission.
- EC (2016c) The Added Value of Natural Capital Accounting for EU policies. KIP INCA Phase 1. European Commission, DG Environment.
- EC (2016d). Implementing an EU system of accounting for ecosystems and their services. KIP-INCA Phase 1 report. European Commission.
- EEA (2015) 'European ecosystem assessment: Concept, data, and implementation', EEA Technical Report No 6/2015. European Environment Agency.
- Economist, The (2010) 'Better REDD than dead: A special report on forests'. Economist website. Available from: <http://www.economist.com/node/17062737>
- Ecosystem Markets Task Force (2013). Realising nature's value: The Final Report of the Ecosystem Markets Task Force. Available from: https://www.gov.uk/government/uploads/system/uploads/attachment_data/file/316101/Ecosystem-Markets-Task-Force-Final-Report-.pdf
- Edens, B., Hein, L. (2013). Towards a consistent approach for ecosystem accounting. *Ecological Economics* 90 (2013) 41–52
- Environmental Economic Accounts Compendium (2015). Statistics South Africa (StatsSA). Available from: <http://www.statssa.gov.za/?p=4341>
- European Commission (2011) The EU Biodiversity Strategy to 2020. Luxembourg: Publications Office of the European Union. Available from: <http://ec.europa.eu/environment/nature/info/pubs/docs/brochures/2020%20Biod%20brochure%20final%20lowres.pdf>
- Eurostat (2015). Forestry Statistics. Available from: http://ec.europa.eu/eurostat/statistics-explained/index.php/Forestry_statistics
- Farley, J. (2012). Natural Capital. The Berkshire Encyclopedia of Sustainability: *Ecosystem Management and Sustainability*. Available from: <http://www.uvm.edu/~jfarley/publications/Natural-Capital-Farley.pdf>

- Fish, R.D., Burgess, J., Church, A. and Turner, R.K. (2011). Chapter 24: Shared values for the contributions ecosystem services make to human well-being. UK National Ecosystem Assessment. United Nations Environment Programme. <http://uknea.unep-wcmc.org>
- Garnåsjordet, P.A. and Megan, N. (2016) 'Delineation of spatial units in Ecosystem Accounting'. Presentation at the London Group on Environmental Accounting, Oslo, 28-30 September 2016. Statistisk sentralbyrå/ Statistics Norway.
- Gomez-Baggethun, E. & Ruiz-Perez, M. (2011) Economic valuation and the commodification of ecosystem services. *Progress in Physical Geography*. 35 (5), pp. 613-628.
- Gómez-Baggethun, E., Martín-López, B. Barton, D. Braat, L. Saarikoski, H. Kelemen, M. García-Llorente, E., van den Bergh, J. Arias, P. Berry, P. L., Potschin, M. Keene, H. Dunford, R. Schröter-Schlaack C., Harrison P. (2014) State-of-the-art report on integrated valuation of ecosystem services. European Commission FP7, pp. 1–33.
- Greenbiz (2016) Why business leaders are cheering the new Natural Capital Protocol. Greenbiz website. Available from: <https://www.greenbiz.com/article/why-business-leaders-are-cheering-new-natural-capital-protocol>
- Grima, N., Singh, S., Smetschka, B. & Ringhofer, L. (2016) Payment for Ecosystem Services (PES) in Latin America: Analysing the performance of 40 case studies. *Ecosystem Services*. 17pp. 24–32.
- De Groot, R.S., Wilson, M.A. & Boumans, R.M.J. (2002) A typology for the classification, description and valuation of ecosystem functions, goods and services. *Ecological Economics*. 41, pp. 393–408.
- Hein, L. *et al.* (2016) Defining Ecosystem Assets for Natural Capital Accounting. PLOS ONE. <http://dx.doi.org/10.1371/journal.pone.0164460>.
- de Jong, R., Edens, B., van Leeuwen, N., Schenau, S., Remme, R., Hein, L. (2016) Ecosystem Accounting Limburg Province, the Netherlands. Technical Report. Statistics Netherlands and Wageningen University. Available from: <https://www.WAVESpartnership.org/en/knowledge-center/ecosystem-accounting-limburg-province-netherlands-part-1-physical-supply-and>
- MA (2005) Millennium Ecosystem Assessment Ecosystems and Human Well-being: Policy Responses. Vol 3. Island Press: Washington DC, US.
- Maes, J., Teller, A., Erhard, M. et al. (2013) Mapping and Assessment of Ecosystems and their Services. An analytical framework for ecosystem assessments under action 5 of the EU biodiversity strategy to 2020. Publications office of the European Union, Luxembourg.
- Metz, B. Davidson, O.R., Bosch, P.R., Dave, R., Meyer, L.A. (eds) (2007) Contribution of Working Group III to the Fourth Assessment Report of the Intergovernmental Panel on Climate Change, 2007. Cambridge University Press, Cambridge, United Kingdom and New York, NY, USA.
- Monbiot, G. (2014) SPERI Annual Lecture, Sheffield University, 2014 <http://www.monbiot.com/2014/07/24/the-pricing-of-everything/>
- Mulder I, Mitchell A W, Peirao P, Habtegabber K, Meneses L, Simonetti R (2012) The NCD roadmap: 4 steps to implement the Natural Capital Declaration for the financial industry, UNEP FI, Global Canopy Programme, and FGVces. http://www.naturalcapitaldeclaration.org/wp-content/uploads/2012/07/NCD_Roadmap.pdf
- Natural Capital Declaration/UNEP/GCP (2013). Implementing the four commitments of the Natural Capital Declaration. UNEP. Available from: http://www.unepfi.org/fileadmin/documents/ncd_roadmap.pdf

- Nel, J.L. & Driver, A. (2015) *National River Ecosystem Accounts for South Africa*. Discussion document for Advancing SEEA Experimental Ecosystem Accounting Project, October 2015. South African National Biodiversity Institute, Pretoria.
- Norton, B.G. & Noonan, D. (2007) Ecology and valuation: Big changes needed. *Ecological Economics*. 63, pp. 664–675.
- Nowak, D.J., Hirabayashi, S., Bodine, A., Greenfield, E. (2014). Tree and forest effects on air quality and human health in the United States. *Environmental Pollution*, Volume 194, Pages 119–129
- Nunes, P.A.L.D., Kumar, P., Dedeurwaerdere, T. (2014). *Handbook on the Economics of Ecosystem Services and Biodiversity*. Edward Elgar Publishing.
- Nunes, P.A.L.D., Varma, A. (2015). Success Stories in Mainstreaming Ecosystem Services into Macroeconomic Policy and Land Use Planning: Evidence from Chile, Trinidad and Tobago, South Africa and Viet Nam. *United Nations Environment Programme*. Available from: www.reliefweb.int/sites/reliefweb.int/files/resources/Global%20synthesis%20report.pdf
- Obst, C. and Vardon, M. (2014) Recording environmental assets in the national accounts. *Oxf Rev Econ Policy* (2014) 30 (1): 126-144. DOI: <https://doi.org/10.1093/oxrep/gru003>
- Obst, C. (2015). How the SEEA Experimental Ecosystem Accounting framework could be used for growth accounting and productivity analysis. OECD Expert Workshop. Available from: <https://www.oecd.org/tad/events/Session%202%20Carl%20OBST%20PAPER.pdf>
- Obst, C., Hein, L., Edens B. (2016) National Accounting and the Valuation of Ecosystem Assets and Their Services. *Environmental and Resource Economics*, Volume 64, Issue 1, pp 1–23
- ONS (2015). Natural Capital Accounting 2020 Roadmap — Office for National Statistics (UK). Available from: <https://www.ons.gov.uk/economy/nationalaccounts/uksectoraccounts/methodologies/naturalcapital>
- ONS (2015) ‘Statistical bulletin: UK Environmental Accounts: 2015’. Office for National Statistics: Newport. Available from: <https://www.ons.gov.uk/economy/environmentalaccounts/bulletins/ukenvironmentalaccounts/2015-07-09>
- Parks, S. & Gowdy, J. (2013) What have economists learned about valuing nature? A review essay. *Ecosystem Services*. 3, pp. 1–10.
- Pascual, U., Termansen, M., Hedlund, K., Brussaard, L., Faber, J., Foudi, S., Lemanceau, P. & Jørgensen, S. (2015) On the value of soil biodiversity and ecosystem services. *Ecosystem Services*. 15pp. 11-18.
- Patil, G.P., Lange, G-M., Jain, S., Mealey, E., Narain, U., Delos Angeles, M.S., Behrendt, H., Naikal, E., Cantrell, J., Aguilar, G. (2012). Moving Beyond GDP, How to factor natural capital into economic decision making. *WAVES Partnership*. Available from: https://www.WAVESpartnership.org/sites/WAVES/files/images/Moving_Beyond_GDP.pdf
- Patil, G.P., Lange, G-M., Jain, S., Mealey, E., Narain, U., Delos Angeles, M.S., Behrendt, H., Naikal, E., Cantrell, J., Aguilar, G. (2012). A Smarter GDP: Factoring natural capital into economic decision-making. *WAVES Partnership*. Available from: http://www.WAVESpartnership.org/sites/WAVES/files/images/A_Smarter_GDP.pdf
- Peskin, H. and Delos Angeles, M.S. (2001). Accounting for Environmental Services: Contrasting the SEEA and the ENRAP Approaches. *The Review of Income and Wealth*. Volume 47, Issue 2 Pages 203–219

- Petersen, J.-E. and Gocheva, K. (2015) 'EU reference document on natural capital accounting', prepared as part of the EU MAES (Mapping and Assessment of Ecosystems and their Services) process. Available from: <http://projects.eionet.europa.eu/ecosystemcapital-accounting/library/reference-document-natural-capital-accounting/final-revised-referencedocument-nca-consultation-january-2015>.
- Pittini M., Smith C., Harlow J., Khan J. and Harris R. (2013) Towards a valuation strategy for natural capital accounting in the UK Roadmap. Produced for Defra-ONS, "Valuation for Natural Capital Accounting Seminar".
- Porras, I. (2016). The water sector in Guatemala: a cup half-full or half-empty? WAVES Partnership Guatemala water briefing. Available from: <https://www.WAVESpartnership.org/sites/WAVES/files/kc/Guatemala%20water%20briefingFINAL.pdf>
- Radermacher, W. (2015) 'Environmental sustainability an interdisciplinary approach to new metrics'. Presentation at HLEG thematic workshop on measuring economic, social and environmental resilience, Rome, 2015.
- Rapacioli, S., Lang, S., Osborn, J., Gould, S. (2014). Accounting for Natural Capital: the elephant in the boardroom. Chartered Institute of Management Accountants. Available from: http://www.cimaglobal.com/Documents/Thought_leadership_docs/Sustainability%20and%20Climate%20Change/CIMA-accounting-for-natural-capital.pdf
- Reed, M.S., Moxey, A., Prager, K., Hanley, N., Skates, J., Bonn, A., Evans, C.D., Glenk, K. & omson, K. (2013) Improving the link between payments and the provision of ecosystem services in agri- environment schemes. *Ecosystem Services*. 9, pp. 44–53.
- Remme, R.P., Edens, B., Schröter, M., Hein, L., (2015) Monetary accounting of ecosystem services: A test case for Limburg province, the Netherlands. *Ecological Economics* 112, 116-128
- Remme, R.P., Schröter, M., Hein, L. (2014) Developing spatial biophysical accounting for multiple ecosystem services. *Ecosystem Services* 10 (December 2014): 6-18
- Science for Environment Policy (2015) *Ecosystem Services and the Environment*. In-depth Report 11 produced for the European Commission, DG Environment by the Science Communication Unit, UWE, Bristol. Available at: <http://ec.europa.eu/science-environment-policy>.
- SEEA-EEA CF and EEA (2012). System of Environmental-Economic Accounting. Central Framework and Experimental Ecosystem Accounting available from: http://unstats.un.org/UNSD/envaccounting/eea_project/default.asp
- SEEA brochure. (no date) The System of Environmental-Economic Accounts (SEEA) Measurement Framework in Support of Sustainable Development and Green Economy Policy. Available from: www.unstats.un.org/unsd/envaccounting/Brochure.pdf
- Schägner, J.P., Brander, L., Maes, J. & Hartje, V. (2013) Mapping ecosystem services' values: Current practice and future prospects. *Ecosystem Services*. 4, pp. 33–46.
- Schröter, M., van der Zanden, E.H., van Oudenhoven, A.P.E., Remme, R.P., Serna-Chavez, H.M., de Groot, R.S. & Opdam, P. (2014) Ecosystem Services as a Contested Concept: A Synthesis of Critique and Counter-Arguments. *Conservation Letters*. 7(6), pp. 514–523.
- Shepherd, E.; Milner-Gulland, E.J., Knight, A.T.; Ling, M.A.; Darrah, S.; van Soesbergen, A., Burgess, N.D. (2016) Status and Trends in Global Ecosystem Services and Natural Capital: Assessing Progress Toward Aichi Biodiversity Target 14. *Conservation Letters* 9(6):429-437.

- Smith, S., Rowcroft, P., Everard, M., Couldrick, L., Reed, M., Rogers, H., Quick, T., Eves, C. and White, C. (2013). Payments for Ecosystem Services: A Best Practice Guide. Defra, London. Available from: https://www.gov.uk/government/uploads/system/uploads/attachment_data/file/200920/pb13932-pes-bestpractice-20130522.pdf
- SNA (2008) *System of National Accounts 2008*, European Commission, International Monetary Fund, Organisation for Economic Co-operation and Development, United Nations, World Bank, 2009.
- Stiglitz, J. (2009). Comment on launching Report by the Commission on the Measurement of Economic Performance and Social Progress. Report available from: <http://www.stat.si/doc/drzstat/Stiglitz%20report.pdf> Comment in New York Times: <http://www.nytimes.com/2009/09/23/business/economy/23gdp.html>
- Sustainable Development Goals (2016). United Nations Development Programme. Available from: <http://www.undp.org/content/undp/en/home/sustainable-development-goals.html>SDG, 2016
- Tacconi, L. (2012). Redefining payments for environmental services. *Ecological Economics*, 73 (1): 29-36.
- Turner, R. K. and Schaafsma, M. (eds.) (2015) *Coastal Zones Ecosystem Services: from Science to Values and Decisionmaking*. Studies in Ecological Economics 9. Springer: Switzerland.
- UN (2014) System of Environmental- Economic Accounting 2012 — Experimental Ecosystem Accounting. Available from: http://unstats.un.org/unsd/envaccounting/seeaRev/eea_final_en.pdf
- UNEP-WCMC (2015) *Experimental Biodiversity Accounting as a component of the System of Environmental-Economic Accounting Experimental Ecosystem Accounting (SEEA-EEA)*. Supporting document to the Advancing the SEEA Experimental Ecosystem Accounting project. United Nations. UNEP.
- UNSTAT (2016) Cover Note for Session 3.b - SEEA Experimental Ecosystem Accounting Eleventh Meeting of the UN Committee of Experts on Environmental-Economic Accounting New York, 22-24 June 2016. Session Organizer: Eurostat. ESA/STAT/AC.322; UNCEEA/11/3b. https://unstats.un.org/unsd/envaccounting/ceea/meetings/eleventh_meeting/UNCEEA-11-3b.pdf
- Wang, J., Uhde, S. & Bordt, M. (2012). Ecosystem accounting – Policy applications. Melbourne, Australia: Expert meeting on ecosystem accounts, 16-18 May 2012.
- Ward, J., de Battista, G. (2016). Modeling the Impact on South Africa's Economy of Introducing a Carbon Tax. Report commissioned by the PMR Secretariat for the National Treasury of South Africa. Government of South Africa. Partnership of Market Readiness, World Bank Group. Available from: http://www.treasury.gov.za/comm_media/press/2016/2016111001%20-%20Carbon%20Tax%20Modelling%20Report%20Final%20Oct%202016.pdf
- WAVES (2017). Guatemala country report. WAVES Partnership. Available from: <http://www.WAVESpartnership.org/sites/WAVES/files/images/Country%20Report%20Guatemala.pdf>
- WAVES (2016a) Philippines Country Report. WAVES Partnership. Available from: <https://www.wavespartnership.org/en/knowledge-center/philippines-waves-country-report-2016>

- WAVES (2016b). Costa Rica country report. WAVES Partnership. Available from: <https://www.wavespartnership.org/en/knowledge-center/costa-rica-waves-country-report-2016>
- WAVES (2016c). Colombia country report. WAVES Partnership. Available from: <https://www.wavespartnership.org/en/knowledge-center/waves-colombia-country-report-2016>
- WAVES (2015). Policy Briefing: Ecosystem Accounts Inform Policies to Manage Competing Demands on Southern Palawan's Resources. WAVES Partnership. Available from: <http://pcsd.gov.ph/wp-content/uploads//2016/03/20a-Policy-Briefing-Preliminary-Ecosystem-Accounts.pdf>
- WAVES (2013). The 50:50 Initiative: Next Steps. WAVES Partnership website. Available from: <https://www.WAVESpartnership.org/en/5050-initiative-next-steps>
- Weber, J.-L. (2015). Ecosystem Natural Capital Accounts: A Quick Start Package. For implementing Aichi Biodiversity Target 2 on Integration of Biodiversity Values in National Accounting Systems in the context of the SEEA Experimental Ecosystem Accounts. Workshop presentation at SUB-REGIONAL CAPACITY BUILDING WORKSHOP ON SUSTAINABLE FINANCE AND RESOURCE MOBILIZATION FOR BIODIVERSITY FOR CARICOM MEMBER STATES, St. John's, Antigua and Barbuda, 18-21 May 2015. Available from: <https://www.cbd.int/doc/meetings/fin/rmws-2015-01/other/rmws-2015-01-presentation-10-en.pdf>
- Whitham CEL, Shi K, Riordan P (2015) Ecosystem Service Valuation Assessments for Protected Area Management: A Case Study Comparing Methods Using Different Land Cover Classification and Valuation Approaches. *PLoS ONE* 10(6): e0129748. doi:10.1371/journal.pone.0129748
- World Bank (2012). Environment matters at the World Bank : Rio+20. Working Paper. World Bank: Washington DC. Available from: <http://documents.worldbank.org/curated/en/2012/01/16565839/environment-matters-world-bank-rio20>
- WWF (2014). Accounting for Natural Capital in EU Policy Decision-Making — A WWF Background Paper on Policy Developments. WWF Germany. Available from: http://awsassets.panda.org/downloads/background_accounting_for_natural_capital_in_eu_policy_decision_making_final.pdf

